



PLASTICA ALFA

PPR-SYSTEM Technical catalogue



ALFAIDRO
ALUMINIUM
PPR-ALPPR MULTILAYER PIPE

ALFAIDRO
PP-R PIPES AND FITTINGS

ALFAIDRO
OFASER
MULTILAYER PP-R PIPE WITH FIBERS



Since 1983 **Plastica Alfa** develops innovative polymer based products for water management and under the constant guidance of its CEO **Mario Pace** has succeeded in entering into the overseas market. Dating from 1990, thanks to **Alfaidro system** production, **Plastica Alfa** has become a solid industrial reality in the global market for pipes and fittings polypropylene random processing.



For the past twenty years the production department has always been improving production lines and new products, thanks also to the new technologies employed: at the moment



Plastica Alfa's portfolio includes over **4400 items** divided into 600 types for different fields of application: **irrigation, hydraulics, thermo-hydraulics and oil&gas**. It is constantly enlarging with new products designed on the basis of the market and customers' demands. In this way several functional new products have been developed and implemented such as **Alfaidro Faser**, a multilayer PPR pipes reinforced by an intermediate layer of special fibers, and or **MULTYPEXALFA** an integrated cross linked polyethylene coextruded with an aluminium layer, specific for water supply and heating and cooling systems. In 2012 **Plastica Alfa** has developed two innovative products:



the first one is **"NO FIRE"** a composite polymer based for firefighting applications and the second is the functionalized PA/PPR system for advanced application where specific chemical resistance properties are requested. The two new systems are made by **advanced coextrusion process**.



Plastica Alfa's R&D Department is constantly developing innovative products and systems for water management focused on energy saving, smart materials, smart monitoring systems for agriculture, smart cities, green buildings.

Since a long time our focal point is the **Quality Management**, intended not only as a system of international standards, **ISO 9001** and **14001** according to which we work and arrange production, but above all as a system of reference that guarantees our commitment for a continuous improvement respecting the environment.

All **PLASTICA ALFA PRODUCTS** are totally **MADE IN ITALY**: designed, tested and assembled with **ITALIAN** materials and methods only.



Technical catalogue

The traditional line of monolayer **PPR Alfaidro pipes** has been enlarged by innovative composite pipes in **PPR-PPGF-PPR Alfaidro Faser** and **Multilayer PPR-Al-PPR Alfaidro Aluminium** pipes in order to satisfy the multiple requests from hydraulics, heating and conditioning, granting the advantages of the intermediate fiberglass and aluminium layers respectively.

ALFAIDRO
ALUMINIUM
PPR-AL-PPR MULTILAYER PIPE

ALFAIDRO
PP-R PIPES AND FITTINGS

ALFAIDRO
OFASER
MULTILAYER PP-R PIPE WITH FIBERS



Contacts

Dott.ssa Marianna Nucifora
Test & Check Laboratory
laboratorio@plasticalfa.it

Dott.Ing Sergio Scaminaci
Technical Department
techdpt@plasticalfa.it

Giuseppe Moschella
Graphic&communication
comunicazione@plasticalfa.it

Plastica Alfa - July 2014 - © all right reserved



1 System characteristics **5-18**

1.1	Fields of employment	6
1.2	Advantages and characteristics	8



2 Standards and Quality **19-24**

2.1	Reference standards	20
2.2	Quality assurance	22



3 Operating Conditions **25-28**



4 Design **29-50**

4.1	Dimensioning of hot and cold water piping systems - Detailed method	30
4.2	Dimensioning of hot and cold water piping systems - Simplified method	37
4.3	Pressure Losses	39



5 Installation

51-70

5.1	Thermal expansion	52
5.2	Insulation and condensate	59
5.3	Joining methods	60
5.4	System inspection	67
5.5	Instruction & warnings	69
5.6	Laying examples	70



6 System components

71-84

6.1	Alfaidro Pipe	72
6.2	Alfaidro Fittings	77
6.3	Tools	86



7 Services and guarantees

87



ALFAIDRO

SYSTEM **1**
CHARACTERISTICS

1.1 FIELDS OF EMPLOYMENT

Alfaidro, Alfaidro Faser and Alfaidro Aluminium find great exploitation in some specific applications:

■ **Hot and cold potable water supply**

in civil and public building, such as residential buildings, hotels hospitals, office, school and many other buildings.

■ **Industrial systems**

for the supply of calcareous water, oils, highly corrosive liquids and food liquids [see table 1.1: "Resistance to chemicals and other media].

■ **Underfloor heating systems**

thanks to PPR high flexibility and the possibility of covering the system with cement.

■ **Radiator systems**

where it is necessary to estimate the thermal expansion.

■ **Compressed air systems**

these systems are free from corrosion, protected from rust and debris.

■ **Means of transport & Shipyards**

ships, planes, caravans, etc, where chemical resistance to brackish water, lightness and capacity of absorption of means in motion vibrations are of fundamental importance;

■ **Ground-source heat pump systems**

and other applications requiring pipe burial;

■ **Hydronic heating and cooling distribution**

systems in which the water is the heat transfer fluid (fan-coil, chiller, heat pumps).

■ **Recycled water and rainwater applications**

thanks to the versatility of these systems

■ **Food industry**

the PPR and all components of these systems are absolutely atoxic, incapable of making over tastes and/or odours

■ **Swimming pool systems**

where pipes are in permanent contact with aggressive chemicals [for information regarding chemical compatibility refer to table 1.1]

■ **Agricultural applications**

where chemical resistance to fertilizers and herbicides and to freezing of the liquid into the pipe are required.



Genova - Shipyards



Radiator systems



Hotel De rance - Tangerang



Compressed air system

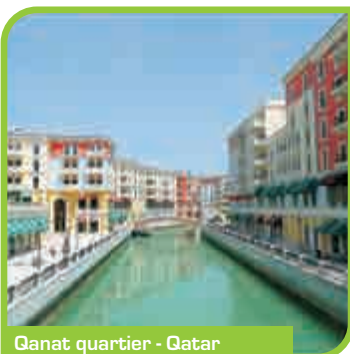

Qanat quartier - Qatar



Caravans



Irrigation plants - Cuba



LEGEND

- 1 Underfloor heating system
- 2 Solar system
- 3 Sanitary system
- 4 Rainwater review
- 5 Heat pump systems



In the table below are shown the comparative field of application of **Alfaidro Systems**

Fields of employment	ALFAIDRO PP-R PIPES AND FITTINGS	ALFAIDRO OFASER MULTILAYER PP-R PIPE WITH FIBERS	ALFAIDRO ALUMINIUM PP-R ALPPR MULTILAYER PIPE
Hot and cold potable water supply	●	●	●
Industrial systems	○	●	●
Underfloor heating systems	○	●	●
Radiator systems	○	●	●
Hydronic heating and cooling distribution	○	●	●
Food industry	●	●	●
Shipyards	●	●	●
Recycled water and rainwater applications	●	●	●
Compressed air systems	●	●	●
Means of transport	●	●	●
Ground source heat pump systems	○	●	●
Agricultural applications	●	●	●
Swimming pool systems	●	●	●
Outside building	-	-	●

● recommended for its technical characteristics

○ suitable for use

- unsuitable

- 1 SYSTEM CHARACTERISTICS
- 2 STANDARDS AND QUALITY
- 3 OPERATING CONDITIONS
- 4 DESIGN
- 5 INSTALLATION
- 6 SYSTEM COMPONENTS
- 7 SERVICE AND GUARANTEE



1.2 ADVANTAGES AND CHARACTERISTICS

As described in more detail in the following sections, **Alfaidro** is a complete pressure pipe system, characterized by:

- outstanding workability.
- excellent weldability and homogeneity of the jointing.
- high impact resistance.
- resistance to corrosion and chemicals.
- low pressure loss, absence of incrustation.
- High-temperature stabilization.
- good environmental compatibility.
- preservation of the organoleptic properties of the conveyed liquids.

All that makes **Alfaidro systems** suitable for a wide range of applications.

Alfaidro system includes **faser-composite PPR pipes** reinforced by an intermediate layer of special glass fibers that adds to the advantages and features already exposed for the PPR pipes Alfaidro those of the intermediate layer. The pipe is produced by coextrusion: the three layers are processed and extruded at the same time, in this way the pipe results perfectly homogeneous and uniform, ensuring high performances.



Some advantages compared with monolayer pipes are:

- thermal expansion reduced by 75%
- reduced amount of fixing points
- higher mechanical stability
- increased flow rate
- lower pressure losses

The low concentration of glass fibers does not influence fusion and recycling process, leaving unchanged installation and use.

Alfaidro Aluminium system includes multilayer pipes in PPR-Al-PPR and it consists of PPR pipes that meet the diameters of the metric series, covered by an aluminum alloy layer and an external layer of black PPR; the three layers are joined by a special polymer acting as adhesive. Before welding, it is necessary to remove the aluminum layer using the appropriate pipe-skinner.

Alfaidro Aluminium system is a perfect combination of metal and plastic pipe since it grants the advantages of both types eliminating all the disadvantages.

The presence of the aluminum layer creates an oxygen barrier protecting the internal PPR layer from oxidation avoiding the bacterial and alga proliferation inside the pipes; moreover it reduces the thermal expansion of more than 80% making installation easier thanks to the reduced quantity of fixed and sliding points.

Finally the external layer in black PPR grants a further barrier against UV rays and a higher resistance to ageing allowing installation of **Alfaidro Aluminium** pipes outdoor.

Thanks to their dimensional stability **Alfaidro Faser** and **Alfaidro Aluminium system** systems are best suited for chilled water, hydronic heating and various industrial applications. Moreover they can be joined with the whole range of **Alfaidro fittings** using the traditional welding techniques.





Raw material granules



Petrochemical plant



PPR DSC curves



Melt flow index determination



Tensile module determination

■ Raw material characteristics

All components of the systems **Alfaidro**, **Alfaidro Faser** and **Alfaidro Aluminium** are produced with **PP-R 80**, a random polypropylene with a high molecular weight, characterized by high impact resistance and workability, even to temperatures below 0°C, a very good resistance to creep and long term heat stabilization; all that makes it particularly suitable for applications requiring high resistance to temperature and pressure.

The outstanding combination of properties which makes PPR a natural choice to manufacture pipes and fittings intended for hot and cold water supply includes: moderate weight, resistance to corrosion and chemicals, low pressure loss, absence of incrustation, good environmental compatibility and preservation of the organoleptic properties of the conveyed liquids.

Upon request, ALFAIDRO pipes produced with **PP-RCT** are also available, a new generation of polymer having an increased resistance to long-term temperature.

Following the curves of **PPR** and **PP-RCT** strenght are shown.

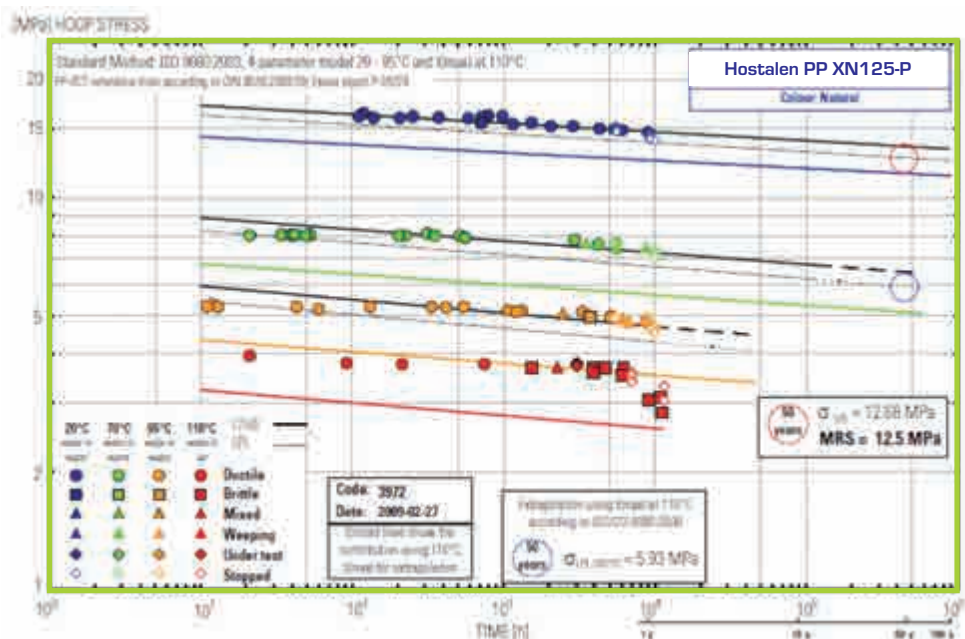
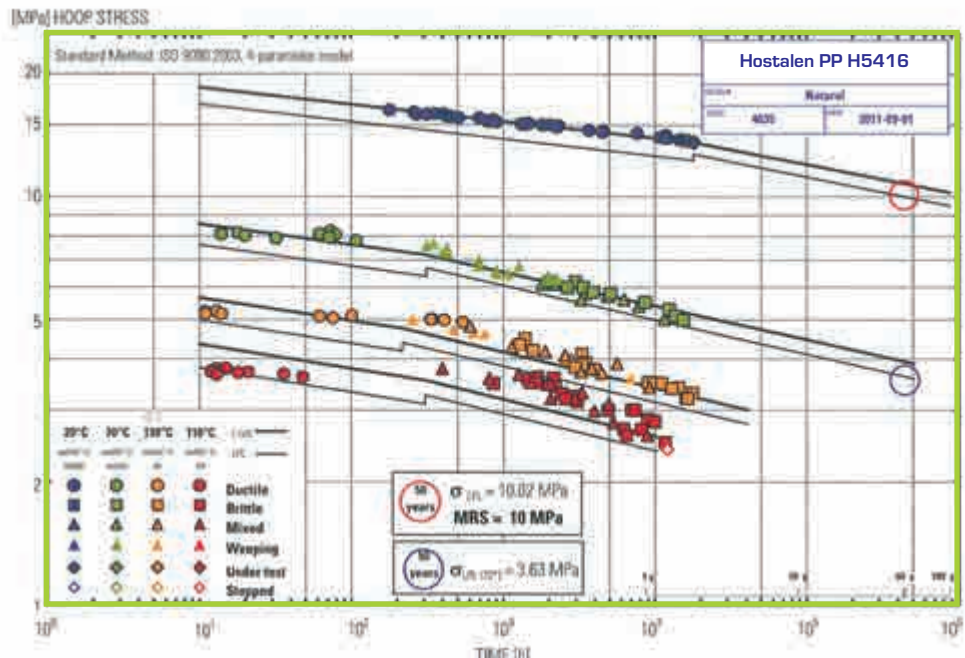



■ Atoxic and organoleptic properties

The raw material and the components used to manufacture **Alfaidro pipes and fittings** are intended for contact with drinking water, are absolutely atoxic, incapable of making over tastes and/or odours and they comply with the prescriptions of the sanitary regulation of **DM (Health) of 6 april 2004 n°174, DM 23/04/2009, Reg. UE n° 10/2011** and with the applicable national and international standards concerning materials intended for drinking water supply and food contact.



Besides the special pigmentation of the pipes makes them opaque, avoiding light from entering and preventing the microbiological growth. Moreover, in the **Alfaidro Aluminium** pipes the aluminium layer create an oxygen barrier that is an additional precaution against the bacterial and alga proliferation inside the pipes.

This protection against the microbiological build-up also increases the service life of the system.

The hygienic safety of Alfaidro systems is also evidenced by **IIP (Istituto Italiano dei Plastici)**, that annually performs for its own account potability tests, and by the **French ACS (Attestation de Conformite Sanitaire)**. For the certificates see section 2.2.



■ Watertight of threaded fittings

The threaded fittings grant watertight assembly by metallic elements.

The special design with dovetail joints at the base of the insert, the grooves and the serrations along the outer circumference, has been designed for maximum anchorage with the plastic material.

This ensures the absolute impossibility of escaping or rotation of the inserts from the body of the fitting.

Furthermore, the surface in contact with the water is completely covered by the plastic material; providing better assurance of potability, chemical and mechanical resistance.



■ Complete system range

A complete range of pipes, fittings, valves and accessories allows to carry out the installation without any problem, in a reduced time compared to a traditional installation and with maximum quality.



■ Full system compatibility and adaptability

The **Alfaidro System** offers a wide range of flanged, grooved and threaded adaptors for connections to equipment and to other types of pipe.

■ High-temperature stabilization

The **PPR Alfaidro** has an increased long-term heat stabilization, it resists to the dangerous effects of peak temperatures and provide higher safety parameters (see section 3 "operating conditions").



■ **Workability**

The low PPR density makes the pipes and fittings extremely light and than easy to handle; moreover the great easiness of cutting and jointing, due respectively to low tensile modulus and melting temperature, facilitates assembling and welding.

■ **Low pressure loss**

The melting temperature and flow rate values of **PPR Alfaidro** denote great material workability that, together with a forefront production technology, allows to obtain pipes and fittings with very low surface roughness, consequently reducing the pressure loss (see section 4.2). Moreover PPR is chemically inert towards salts dissolved in water avoiding the risk of incrustations causing obstructions in metallic pipes.

This also means reduced pumping energy and high energy efficiency.

■ **High resistance to creep**

The tensile modulus and elongation at break values make **Alfaidro, Alfaidro Faser and Alfaidro Aluminium** products resistant to cracking under stressing at high temperature (see section 3). Moreover, because of PPR high elasticity, the pipe enlarges its section in consequence of the volume increase connected to the liquid freezing, preventing from dangerous cracking. Moreover, thanks to elasticity, PPR products result particularly resistant to over-pressure produced by “water hammer”. (This is the consequence of an instantaneous and quick turning off of a tap that suddenly stops the water flow: the energy of the liquid in motion is transformed in work that, having repercussions on the pipe walls, might break the pipe).

■ **High impact resistance**

Pipes and fittings assure good handling during the laying operations, reducing the bursting risks and the damages due to accidental impacts to a minimum; operating at temperatures below 0 °C reached during transportation and/or storage in the open, the impact resistance value gets lower and more care is necessary.

■ **Low thermal conductivity**

All three **Alfaidro systems** are very resistant to condensation so that in some cases, it is possible to avoid the pipes insulation (the condensation temperature is shown in table 5.2). The PPR low thermal conductivity reduces the fluid heat loss conveyed, the temperature lowering is reduced to a minimum resulting in power saving follows.

■ **High dielectric rigidity and Low dielectric constant and loss factor**

Alfaidro systems are resistant to electrostatic fields so that in usual conditions there is no perforation due to flashover.

Moreover **Alfaidro** installations are resistant to electromagnetic interference.



LEED standards

Alfaidro system meets the LEED standards. **Plastica Alfa** is able to define which LEED credits the **Alfaidro** products can help and is able to respond adequately to the demands of the parties involved in a project LEED (clients, designers, businesses).

Safe and sustainable buildings

From the characteristics just mentioned, it is clear that **Alfaidro** piping system has all the requirements to ensure a long service life that goes well beyond the fifty years prescribed by reference standards. Following the design parameters given in this catalogue, all the environmental impact due to repairs and leaks will be taken off.



Environmentally friendly

The PPR used for **Alfaidro system** is recyclable and can be minced, melted, and reused for various applications. Moreover, the PPR processing and disposal doesn't produce harmful waste products.

Resistance to corrosion

PPR pipes and fittings are very resistant to solvents and chemicals and therefore they are suitable for industrial installations; moreover no protection from lime and cement is needed (see table 1.1 "Resistance to chemicals and other media").



Resistance to stray currents

Because of their high volume and surface resistivity, all **Alfaidro systems** are insulators and therefore free from electrochemical corrosion that can occur in metallic installations owing to stray currents. This phenomenon becomes significant when the installation is located by stray currents high concentration zones, such as around railways and industrial areas.

Soundproofing

Thanks to its high soundproofing and low tensile modulus, PPR is able to deaden vibrations and noise usually produced in metallic installations in consequence of water hammer and high flow speed.



UV resistance

PPR pipes and fitting (with the exception of the **Alfaidro Aluminium**, as shown below) can not be exposed (unprotected) to the direct radiation of UV rays. For this reason **Alfaidro pipes** are packed in UV-resistant bags, which protect the pipes until they are removed.



Fire Protection

Alfaidro pipes and fittings are classified as B2 according to DIN 4102 (normally flammable).

It is noted that much of the danger of a fire comes from the gas toxicity of the products of combustion, the smoke produced by **Alfaidro** piping materials is mostly water vapour and CO₂, and is not dangerous to people or animals. Against the spread of fire and smoke we recommend the use of fire protection devices. The level of security measures needed depend on the type of installation and vary greatly between Countries.

Generally, if the pipes pass through walls or ceilings subjected to a danger of fire, these pipes must possess the same level of fire resistance. **Alfaidro** pipes fit with all fire protection systems that have the corresponding test certificate.

Fire load it indicates the quantity of heat that can develop as a result of a fire. The values needed to define the fire load are the sum of all flammable materials (electrical wiring, piping, insulation, etc.) present in the concerned area.

The combustion heat V (kWh/m) depends on dimensions and material, the lower heat value Hu = 12.2 kWh/kg (according to DIN 18230-1) and the material mass m (kg/m) are the basis of calculating for **PPR Alfaidro** pipes.

Combustion heat values V (kWh/m) for Alfaidro pipes

D _e (mm)	ALFAIDRO PPR PIPES AND FITTINGS		ALFAIDRO OFASER MULTILAYER PPR PIPE WITH FIBRES	ALFAIDRO ALUMINIUM PPR-AL PPR MULTILAYER PIPE
	S 5 - SDR 11	S 2,5 - SDR 6	S 3,2 - SDR 7,4	S 2,5 - SDR 6
20	-	2.08	1.77	2.01
25	-	3.22	2.81	3.13
32	3.12	5.26	4.52	5.08
40	4.96	8.14	7.03	7.87
50	7.7	12.64	10.95	12.12
63	12.19	20.08	17.21	19.14
75	17.02	28.44	24.48	27.06
90	24.66	40.87	35.05	38.8
110	36.58	61.27	52.49	58.5
125	47.45	78.85	-	-
140	59.14	98.96	-	-
160	77.63	129.02	-	-
180	98.12	159.16	-	-
200	121.01	201.32	-	-
225	153.16	-	-	-
250	188.73	-	-	-
280	236.55	-	-	-
315	299.39	-	-	-

■ Resistance to chemicals and other media

Thanks to PP-R properties, the components **Alfaidro**, **Alfaidro Faser** and **Alfaidro Aluminium** have an exceptionally high resistance to chemicals. PP-R is resistant to aqueous solutions of salts and non-oxidising oxidizing acids, alkalis and many solvents; while aliphatic, aromatic and halogen hydrocarbons, certain oils, fats and waxes cause swelling. This phenomenon is of little relevance at temperatures up to 30°C, but it becomes remarkable from 60 °C onwards. Swelling causes a drop in mechanical strength although the material regains its original properties after the evaporation of the liquids causing swelling.

PP-R has limited resistance to strong oxidizing agents such as nitric acid, chlorosulphonic acid, ozone, fuming sulphuric acid, hydrogen peroxide; it is partially permeable to gases, aliphatic, aromatic and halogen hydrocarbons. Therefore contact with water containing chlorine exceeding the law limits (12.5%) has to be avoided.

Internal stresses induced during manufacture and external stresses due to applied load and high temperature may greatly reduce chemical resistance in a given environment. For this reason the values in the following table can only apply to the raw material not subjected to mechanical or thermal stress. In case of simultaneous presence of mechanical stress, like pressure pipe systems, and exposure to chemical agents it is necessary to carry out specific tests, possibly at high temperature. Complete tables of resistance to chemicals are available upon request and at our web page www.plasticalfa.com.

It must be pointed out that the components with brass element which may come into contact with water, such as the ball in the valves or the inside of the stop cock, chemical resistance is more limited than PP-R; while, in the threaded fittings the surface in contact with the water is completely covered by the PP-R and show the same behavior towards chemicals.

The results of numerous chemical resistance tests are shown in the following table. The test specimens were immersed for 60 days in the test substance without mechanical stress and then tested for swelling, weight loss and tensile properties.

Table 1.1 - PPR Resistance to chemicals and other media

Substances	Concentration %	Behaviour of PPR at		
		20 °C	60 °C	100 °C
A				
Acetic acid (glacial)	100%	+	/ D	-
Acetic acid, [a]	70%	+	+	+
Acetic anhydride	t.g.	+	/ D	-
Acetone	100%	+	+ [b]	
Acetophenone		+	/	
Acrylonitrile	t.g.	+		
Air	t.g.	+	+	+
Alcohol (drinking)		+	+	+ [b]
Alums (all types) [aq]	a	+	+	
2-aminoethanole (ethanolamine)	t.g.	+		
Ammonia, gaseous	100%	+	+	
Ammonia, liquid	100%	+		
Ammonium acetate [aq]	a	+	+	+
Ammonium chloride [aq]	a	+	+	+
Ammonium fluoride [aq]	s	+	+	
Ammonium hydrogen carbonate [aq]	s	+	+	
Ammonium metaphosphate [aq]		+	+	
Ammonium nitrate [aq]	a	+	+	+
Ammonium phosphate [aq]	a	+	+	+
Amyl acetate	t.g.	/	-	
Aniline	a	+	+	
Anisole	100%	/	/	
Aqua regia (HCl + HNO ₃)		-	-	
B				
Barium hydroxide [aq]	a	+	+	
Barium salts [aq]	a	+	+	+
Benzoic acid [aq]	a	+	+	+
Benzoyl chloride		/		
Bleaching solution containing 12.5% active chlorine		/	/	-
Borax (sodium tetraborate) [aq]	s	+	+	+
Boric acid [aq]	a	+	+	+
Bromic acid	concentrated	/		

Substances	Concentration %	Behaviour of PPR at		
		20 °C	60 °C	100 °C
B				
Bromine vapours	high	-	-	-
Bromine vapours	low	/	-	-
Bromine, liquid	100%	-	-	-
Butane, gaseous	100%	+	+	-
Butane, liquid	100%	+	-	-
Butanol [aq]	a	+	-	-
Butinediol	100%	+	+	-
n-Butyl alcohol (n-Butanol)	100%	+	-	-
Butyl acetate	t.g.	/	-	-
Butyl phthalate (dibutyl phthalate)	t.g.	+	/	-
Butylene glycol	t.g.	+	-	-
C				
Calcium carbonate [aq]	cold saturated	+	+	+
Calcium chloride [aq]	cold saturated	+	+	+
Calcium hydroxide		+	+	-
Calcium hypochlorite, aqueous (susp.)	a	+	+	-
Calcium nitrate [aq]	cold saturated	+	+	-
Camphor oil	-	-	-	-
Carbon disulphide	100%	/	-	-
Castor oil		+	+	-
Caustic soda solution	a	+	+	+
Chloric acid [aq]	1%	+	/	-
Chloric acid [aq]	10%	+	/	-
Chloric acid [aq]	20%	+	-	-
Chlorine bleaching solution with 12,5% active chlorine **		/	/	-
Chlorine water	cold saturated	/	-	-
Chlorine, aqueous solution (chlorine water)	cold saturated	/	-	-
Chlorine, gaseous, dry	100%	-	-	-
Chlorine, gaseous, moist	10%	/	-	-
Chlorine, gaseous, moist		-	-	-
Chlorine, liquid	100%	-	-	-
Chloroacetic acid	100%	+	-	-
Chloroacetic acid (mono) [aq]	a	+	+	-
Chloroacetic acid [aq]	< 85%	+	+	-
Chloroform	t.g.	/	-	-
Chlorosulphonic acid	t.g.	-	-	-
Chrome alum (potassium chromic sulphate) [aq]	s	+	+	-
Chromic acid [aq] **	50%	/ D	/ D	-
Citric acid, aqueous	s	+	+	+
Coconut oil		+	+	-
Copper chloride [aq]	s	+	-	-
Copper nitrate [aq]	30%	+	+	-
Copper sulphate [aq]	a	+	+	-
Corn oil		+	/	-
Cottonseed oil	t.g.	+	+	-
Cresol	100%	+	/ D	-
Cyclohexane	100%	+	-	-
Cyclohexanol		+	+	-
Cyclohexanone (anon)		+	/	-
D				
Dekahydronaphthalene (Dekalin)®	t.g.	/	/	-
Dextrin (starch gum) [aq]	18%	+	+	-
Dextrose		+	+	-
Dibutyl phthalate (butyl phthalate)	t.g.	+	/	-
Dichloroacetic acid	t.g.	+	-	-
1,1-Dichloroethylene (vinylidene chloride)	t.g.	-	-	-
Diethanolamine	t.g.	+	-	-
Diethylen ether	100%	/	-	-
Diethylene glycol		+	+	-
Diglycolic acid [aq]	30%	+	+	-
Diisooctyl phthalate	t.g.	+	/	-
Dimethyl formamide	t.g.	+	+	-
Dimethylamine		+	-	-
Diethylphthalate		+	/	-

Substances	Concentration %	Behaviour of PPR at		
		20 °C	60 °C	100 °C
E				
Ethanolamine [2-aminoethanol]	t.g.	+		
Ethyl alcohol	100%	+		
Ethyl chloride (chloroethane)	t.g.	- (b)		
Ethyl ether (diethyl ether)	t.g.	/		
Ethylene chloride	100%	/		
Ethylene glycol		+	+	+
Ethylene oxide, gaseous	t.g.	+		
2-Ethylhexanol		+		
F				
Fluorine, gaseous		-		
Formaldehyde [aq]	up to 40%	+		
Formic acid, aqueous	10%	+	+	
Fructose (fruit sugar), aqueous	a	+	+	+
G				
Gasoline (Standard), DIN 51635		/	-	
Gelatin	a	+	+	
Glacial acetic acid [100% acetic acid]	t.g.	+	/ D	
Glycerin [aq]	a	+	+	
Glycolic acid [aq]	up to 70%	+		
H				
Heptane		/	/	
Hexane		+	/	
Hydrochloric acid	a	+ D	+ D	
Hydrofluoric acid, aqueous	40%	+	+	
Hydrofluoric acid, aqueous	40...85%	+		
Hydrogen		+	+	
Hydrogen chloride gas, dry and moist		+	+ D	
Hydrogen sulphide, aqueous	s	+	+	
Hydroxylamine sulphate, aqueous	12%	+	+	
Hypochlorous acid		+ to /	/	
I-J				
Iodine in potassium iodide solution	3% iodine	+	+	
Iodine tincture, DAB 6	c	+		
Isobutyl alcohol (isobutanol)		+		
Isooctane		+	/	
Isopropanol	t.g.	+	+	
Isopropyl ether	t.g.	/	-	
L				
Lactic acid, aqueous	jede	+	+	+
Lanolin (wool fat)		+	/	
Linseed oil	t.g.	+	+	
Lubricating oil	t.g.	+		
M				
Magnesium carbonate		+	+	
Magnesium chloride [aq]	a	+	+	
Magnesium salts [aq]	a	+	+	+
Magnesium sulphate [aq]	a	+	+	
Malic Acid, aqueous	50%	+	+	
Menthol	100%	+		
Mercury	100%	+	+	
Mercury salts	cold saturated	+	+	
Methanol	t.g.	+	+	
Methyl acetate (acetic acid methyl ester)	t.g.	+	+	
Methyl alcohol (methanol)	100%	+	+	(b)
Methyl bromide (bromomethane), gaseous	t.g.	-		
Methyl ethyl ketone	t.g.	+	/	
Methylamine [aq]	32%	+		
Methylene chloride ** (dichloromethane)		/	(b)	
Milk		+	+	+

Substances	Concentration %	Behaviour of PPR at		
		20 °C	60 °C	100 °C
N				
Naphta/benzene mixture	80/20	/	-	
Nickel chloride		+	+	
Nickel nitrate		+	+	
Nickel sulphate (aq)	a	+	+	
Nitric acid	10%	+	+	
Nitric acid	25%	+	/	
Nitric acid	50%	/	-	
Nitric acid	68%		-	
Nitrobenzene	100%	+	/	
O				
Oils, vegetable and animal		+	+ to /	-
Oleic acid	100%	+	/	
Oleum	a	-	-	+
Olive oil		+	+	
Oxalic acid (aq)	cold saturated	+	/	
Oxygen		+	+	
P				
Parraffin oil		+	/	
Peanut oil	t.g.	+	+	
Perchloric acid (aq)	20%	+	+	
Petroleum ether		+	/	
Phenol (carbolic acid)		+	+ D	
Phosphoric acid (aq)	80 ... 95%	+	+ D	
Phosphorus oxychloride	100%	+	/	
Picric acid (aq)	1%	+		
Potassium borate (aq)	1%	+	+	
Potassium bromate (aq)	up to 10%	+	+	
Potassium bromide (aq)	a	+	+	
Potassium carbonate (potash) (aq)	cold saturated	+	+	
Potassium chlorate	a	+	+	
Potassium chloride	a	+	+	
Potassium chromate (aq)	40%	+	+	
Potassium cyanide (aq)	a	+	+	
Potassium fluoride (aq)	a	+	+	
Potassium hydrogen carbonate (aq)	s	+	+	
Potassium hydroxide	a	+	+	
Potassium iodide	a	+	+	
Potassium nitrate	a	+	+	
Potassium perchlorate (aq)	1%	+	+	
Potassium permanganate	cold saturated	+		
Potassium persulphate	a	+	+	
Potassium sulphate	a	+	+	
Propane, gaseous	t.g.	+	+	
Propionic acid, aqueous	a	+	+	
Pyridine	100%	/	/	
R				
Raw gasoline		/	-	
S				
Salt water	a	+	+	+
Sea water		+	+	+
Silver nitrate (aq)	a	+	+	+
Soda (sodium carbonate) (aq)	a	+	+	+
Sodium acetate (aq)	a	+	+	+
Sodium benzoate (aq)	36%	+	+	
Sodium carbonate (aq)	a	+	+	+
Sodium chlorate (aq)	s	+	+	
Sodium chloride (aq)	a	+	+	+
Sodium hydrogen sulphate (aq)	s	+	+	
Sodium hydrogen sulphite (aq)	s	+	+	
Sodium hydroxide (aq)	a	+	+	
Sodium hydroxide, solid	100%	+	+	

Substances	Concentration %	Behaviour of PPR at		
		20 °C	60 °C	100 °C
S				
Sodium hypochlorite, aqueous (with 12,5% active chlorine)				
Sodium nitrate (aq)	a	+	+	
Sodium perborate (aq)	a			
Sodium silicate (aq)	a	+	+	
Sodium sulphate (aq)	cold saturated			
Sodium sulphide (aq)	s	+	+	
Sodium sulphite (aq)	40%			
Sodium thiosulphate (aq)	s	+	+	
Standard grade petrol				
Sucinic acid (aq)	cold saturated	+	+	
Sulphates, aqueous solutions	a	+	+	
Sulphuric acid	98%	/	-	
Sulphuric acid (aq)	10%	+	+	
Sulphuric acid (aq)	70%	+	/	
Sulphuric acid (aq)	80%	+	/	
Sulphuric acid (aq)	85%	+	/	
Sulphuric acid (aq)	up to 50%	+	+	
Sulphurous acid		+	+	
T				
Tartaric acid (aq)		+	+	
Thiophene	cold saturated	/	-	
Toluene	100%	/	-	
Trichloroacetic acid (aq)	t.g.	+	+	
Triethanolamine	50%	+	+ D	
U				
Urea (aq)	cold saturated	+	+	
W				
Whisky		+		
Wine		+	+	
X				
Xylene	100%	/	-	
Z				
Zinc chloride (aq)	a	+	+	
Zinc sulphate (aq)	a	+	+	+

SIMBOLOGY

- +** = Resistant: swelling < 3 %, weight loss < 0.5 %, elongation at break not altered
- /** = Limited resistance: swelling 3-8 %, weight loss 0.5-5 %, elongation at break reduced less than 50 %
- = Not resistant: swelling > 8 %, weight loss > 5 %, elongation at break reduced more than 50 %
- D** = Discoloration possible
- a** = any percentages **s** = saturated **aq** = aqueous **t.g.** = technical grade **c** = as commercial
- (b)** = measured value at boiling point of test substance
- **** = does not apply to welded joints (included joints produced by thermal bending)
- 1)** = resistance is dependent on composition



ALFAIDRO

STANDARDS
AND QUALITY 2



2.1 REFERENCE STANDARDS

System standards

Alfaidro, Alfaidro Faser and Alfaidro Aluminium pipes and fittings are manufactured in compliance with the following standards:

UNI EN ISO 15874-1, -2, -5, -7: Plastics piping systems for hot and cold water installations. Polypropylene (PP).

UNI EN ISO 21003: Multilayer piping systems for hot and cold water installations inside buildings.

DIN 8077-78: Polypropylene (PP) pipes – PP-H, PP-B, PP-R, PP-RCT.

DIN 16962: Pipe fittings and joint assemblies for polypropylene pressure pipes.

DIN 16837: Multilayer pipes -Plastics-Multilayer pipes - General quality requirements and testing.

BS 4991: Specification for propylene copolymer pressure pipe.

ASTM F238: Standard specification for pressure rated polypropylene (PP) piping systems.

CSA B137.11: Polypropylene (PP-R) pipe and fittings for pressure applications.

CSA B214: Polypropylene (PP-R) pipe and fittings for hydronic applications.

DWG: guidelines.

Installation standards

UNI 9182+A1: Impianti di alimentazione e distribuzione d'acqua fredda e calda - Progettazione, installazione e collaudo.

UNI ENV 12108: Plastics piping systems - Guidance for the installation inside buildings of pressure piping systems for hot and cold water intended for human consumption.

UNI EN 1264-1, -2, -3, -4: Water based surface embedded heating and cooling systems.

ISO 10508: Plastics piping systems for hot and cold water installations.

UNI EN 806-1, -2: Specifications for installations inside buildings conveying water for human consumption.

BS 6700: Design, installation, testing and maintenance of services supplying water for domestic use within buildings and their curtilages Specification.

DIN 1988: Technical Regulations for Drinking Water Installations (TRWI).

DIN 4109: Sound Insulation in Building Constructions.

DIN 18381: Gas, Water and Sewage Installations within Buildings.

DIN 16928: Pipe Connections, Fittings, Laying.



■ **Welding standards**

DVS 2207: Welding of Thermoplastics.

DVS 2208: Machines and Equipment for Welding Thermoplastics.

■ **Potability and suitability for alimentary purposes**

DM (Health) of 6 april 2004 n°174:

Regulation on materials and articles which can be used in stationary collection, treatment, supply and distribution of water intended for human consumption.

DM 23/04/2009:

Updated Decree dd. 21/03/1973, on the hygiene control of packaging, containers and utensils intended to come into contact with foodstuffs or substances for personal use.

Reg. UE n° 10/2011:

Materials and objects in plastics intended to come into contact with foodstuffs.

KTW recommendations:

for plastic materials used in the transport of drinking water.

DVGW-W 270:

Assessment of enhancement of microbial growth on non-metallic materials in contact with drinking water.

BS 6920:

Suitability of non-metallic products for use in contact with water intended for human consumption with regard to their effect on the quality of the water.

FDA criteria in 21 CFR 177.1520:

for food contact applications, excluding cooking, listed under conditions of use C through H in 21 CFR 176.170(c), Table 2, and can be used in contact with all food types as listed in 21 CFR 176.170(c), Table 1.

■ **CPR-Construction Products Regulation and CE marking**

The New Construction Products Regulation (CPR-Construction Products Regulation) No. 305/2011 replaces the CPD-Construction Products Directive 89/106/EEC laying down the harmonized conditions for the marketing of construction products in the European Union.

The CE marking, which is regulated by the CPR 305/2011, on plastic pipes and fittings for water conveyance is not applicable, since the harmonized European standard that defines the requirements for the use of CE marking is not in force yet.

It should be noted also that the CE marking is not a quality mark, as it does not grants the user with regard to the performance characteristics and suitability of the product, whereas it is only a tool for the free circulation of goods within the European market with respect to the fulfillment of the essential safety requirements for the end user.



2.2 QUALITY ASSURANCE

Plastica Alfa main aim is to provide high quality products so as to satisfy the customers needs. In order to do that, our products are subjected to a strict program of tests and checks verifying the quality during all production phases: since the raw material arrival to the finished products. The tests are carried out according to precise procedures developed inside the company making reference to the current technical standard, in order to get accurate and reproducible data. **Plastica Alfa laboratory** is equipped with advanced instruments and run by skilled staff testing raw materials and products for mechanical, thermal and physical characteristics.

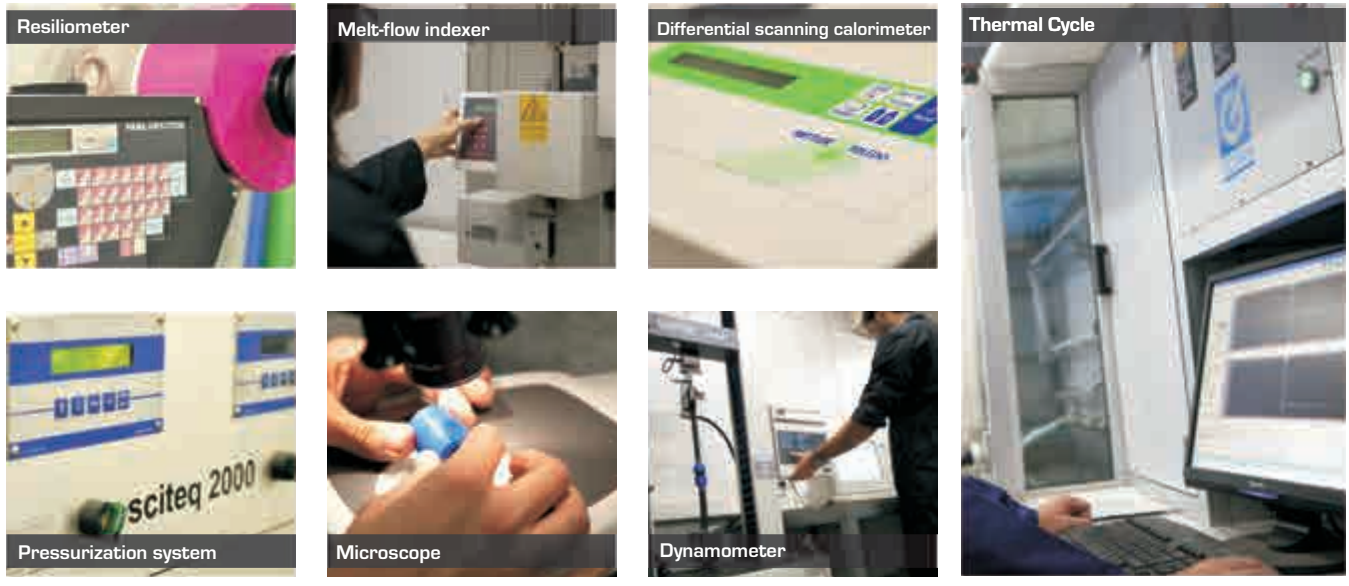

■ Production control plan

The granulated raw material is accepted only if accompanied by the certificate of analysis stating the melt flow index value: if it conforms to the requirements stated at the time of the order, the lot is accepted and a sample is tested (MFI) in the laboratory according to the standard **UNI EN ISO 1133**.

The products and process quality controls are carried out during the production by expressly trained personnel and in the laboratory as well. The following table resumes the tests and controls scheduled in the control plan for pipes and fittings

Table 2.1 - Production control plan for Alfaidro pipes and fittings

Verified characteristics	Reference standards
Appearance, dimension and marking	UNI EN ISO 15874-2/3, DIN 8077 - DIN 16962 UNI EN ISO 21003-2, DIN 16837
Internal pressure resistance 1 h, 20 °C, 16 MPa 1 h, 95 °C, 5 MPa 22 h, 95°C, 4.2 Mpa 165 h, 95°C, 3.8 Mpa 1000 h, 95°C, 3,5 MPa	UNI EN 921 ISO 1167
Longitudinal reversion	UNI EN 743
Thermal stability 8760 h, 110 °C, 1.9 Mpa	UNI EN 921 ISO 1167
Impact resistance	ISO 9854-1/2
Determination of melt flow index	UNI EN ISO 1133

The test results are recorded in certificates that, at customer request, follow the goods in order to prove the product compliance with the specified requirements and the effective application of the quality system. Only the batches passing the quality controls are sent to the packaging dept..

Alfaldro pipes&fittings are certified by IIP (see page 24 for products certificates).

The certificates are available in section "certification" at www.plasticalfa.it

All measurement equipment and tools are calibrated using standard samples, in the turn calibrated by qualified centres (ACCREDIA centres, National Calibration Centre).

■ Certificate of Quality Management System

Plastica Alfa has implemented and maintains a Quality Management System which fulfils the requirements of the standard **UNI EN ISO 9001:2008**, it is guaranteed by certificate **No 303** issued by CISQ/Istituto Italiano dei Plastici and recognised in Europe by IQ-NET. The seal of quality assures the customers and the company itself of the reliability of products and the whole Quality Management System of the company.

■ Certificate of Environmental Management System

The safeguard of the environment is an issue of primary importance to Plastica Alfa that has implemented an Environmental Management System fulfilling the requirements of the standard **UNI EN ISO 14001:2004** proved by certificate **No. 022** issued by CISQ-SGA/Istituto Italiano dei Plastici.

It has to be pointed out that PPR has a very low environmental impact and the processes used to manufacture and transforming it are considered among the cleanest in the industrial field. At the end of its available life, PPR is an inert product and it is suitable for many ways of disposal, recycling included.



1 SYSTEM CHARACTERISTICS

2 STANDARDS AND QUALITY

3 OPERATING CONDITIONS

4 DESIGN

5 INSTALLATION

6 SYSTEM COMPONENTS

7 SERVICE AND GUARANTEE





ALFAIDRO

OPERATING
CONDITIONS 3

According to the standards **UNI EN ISO 15874** and **UNI EN ISO 21003** , PPR pipes and fittings are classified according to the application class and the design pressure

Table 3.1 - Classification of service conditions

Application Class 1: Hot Water distribution 60 °C	
Working Temperature	60 °C for 49 years
Maximum working temperature	80 °C for 1 year
Malfunctioning temperature	95 °C for 100 hours
Maximum working pressure	10 bar

Application Class 2: Hot Water distribution 70 °C	
Working Temperature	70 °C for 49 years
Maximum working temperature	80°C for 1 year
Malfunctioning temperature	95 °C for 100 hours
Maximum working pressure	10 bar

Application Class 4: Underfloor heating and low temperature radiators	
Working Temperature	20 °C for 2,5 years followed by 40 °C for 20 years followed by 60 °C for 25 years
Maximum working temperature	70 °C for 2,5 years
Malfunctioning temperature	100 °C for 100 hours
Maximum working pressure	10 bar

Application Class 5: High temperature radiators	
Working Temperature	20 °C for 14 years followed by 60 °C for 25 years followed by 80 °C for 10 years
Maximum working temperature	90 °C for 1 year
Malfunctioning temperature	100 °C for 100 hours
Maximum working pressure	10 bar

All systems which satisfy the conditions specified in table 3.1 shall also be suitable for the conveyance of cold water for a period of **50 years** at a temperature of **20 °C** and a design pressure of **10 bar**.

The **Nominal Pressure (or PN)** is another parameter used to classify the mechanical characteristics of pipes and fittings, it corresponds to the maximum continuous operating pressure in bar, which can be sustained with water at **20 °C**.

Table 3.2 shows the values of maximum permissible operating pressures at different conditions of temperature and the system life, as specified in the standard **DIN 8077**.

Table 3.2 - Maximum permissible operating pressures for PPR pipes and fittings - Safety factor C = 1.25

Temperature (°C)	Service life (years)		 PP-RCT	 	 PP-RCT		
		SDR 11 S5	SDR 9 S4	SDR 7.4 S3.2	SDR 7.4 S3.2	SDR 6 S2.5	SDR 5 S2.0
10	1	21.1	28.8	33,4	36,2	42,0	52,9
	5	20.0	27.9	31,5	35,1	39,8	50,1
	10	19.3	27.5	30,7	34,7	38,5	48,5
	25	18.7	27.1	29,7	34,1	37,3	46,9
	50	18.2	26.7	28,9	33,6	36,3	45,7
	100	17.7	26.3	28,2	33,2	35,4	44,5
20	1	18.0	25.0	28,5	31,5	36,0	45,3
	5	16.9	24.2	26,8	30,5	33,8	42,5
	10	16.4	23.9	26,1	30,1	32,8	41,3
	25	16.0	23.5	25,2	29,6	31,8	40,1
	50	15.5	23.1	24,5	29,2	30,9	38,9
	100	15.0	22.8	23,9	28,8	29,9	37,7
30	1	15.3	21.7	24,2	27,3	30,6	38,5
	5	14.4	20.9	22,7	26,4	28,7	36,1
	10	13.9	20.6	22,1	26,0	27,7	34,9
	25	13.4	20.2	21,3	25,5	26,8	33,7
	50	13.1	19.9	20,7	25,1	26,1	32,9
	100	12.8	19.7	20,1	24,8	25,5	32,1
40	1	12.9	18.6	20,6	23,5	25,8	32,5
	5	12.1	18.0	19,2	22,6	24,2	30,5
	10	11.8	17.7	18,7	22,3	23,6	29,7
	25	11.3	17.3	18,0	21,8	22,6	28,5
	50	11.0	17.1	17,4	21,5	22,0	27,7
	100	10.7	16.8	16,9	21,2	21,3	26,9
50	1	11.0	15.9	17,4	20,1	22,0	27,7
	5	10.2	15.3	16,2	19,3	20,4	25,7
	10	9.9	15.1	15,7	19,0	19,7	24,9
	25	9.6	14.7	15,1	18,6	19,1	24,1
	50	9.3	14.5	14,7	18,3	18,5	23,3
	100	8.9	14.3	14,2	18,0	17,8	22,5
60	1	9.3	13.5	14,7	17,0	18,5	23,3
	5	8.6	13.0	13,6	16,3	17,2	21,7
	10	8.3	12.7	13,2	16,0	16,6	20,8
	25	8.0	12.4	12,7	15,7	15,9	20,0
	50	7.7	12.2	12,3	15,4	15,3	19,2
70	1	7.8	11.3	12,3	14,3	15,6	19,6
	5	7.2	10.9	11,4	13,7	14,3	18,0
	10	7.0	10.7	11,1	13,5	14,0	17,6
	25	6.1	10.4	9,6	13,1	12,1	15,2
	50	5.1	10.2	8,1	12,9	10,2	12,8
80	1	6.5	9.5	10,3	11,9	13,1	16,4
	5	5.7	9.0	9,1	11,4	11,5	14,4
	10	4.8	8.9	7,7	11,2	9,6	12,0
	25	3.8	8.6	6,2	10,9	7,6	9,6
95	1	4.6	7.1	7,3	8,9	9,2	11,6
	5	3.0	6.7	4,9	8,5	6,1	7,6
	10	2.6	6.6	4,1	(8,3)	(5,1)	6,4

- 1 SYSTEM CHARACTERISTICS
- 2 STANDARDS AND QUALITY
- 3 OPERATING CONDITIONS
- 4 DESIGN
- 5 INSTALLATION
- 6 SYSTEM COMPONENTS
- 7 SERVICE AND GUARANTEE

Table 3.3 - Maximum permissible operating pressures for heating, conditioning and Hydronic system

Safety factor C = 1.25

Services Conditions (°C)	Temperature (years)	Service life (years)	ALFAIDRO PPR PIPES AND FITTINGS	ALFAIDRO OFASER MULTILAYER PPR PIPE WITH RESES	ALFAIDRO OFASER MULTILAYER PPR PIPE WITH RESES ALFAIDRO ALUMINIUM PPR-AL PPR MULTILAYER PIPE	ALFAIDRO PPR PIPES AND FITTINGS	ALFAIDRO PPR PIPES AND FITTINGS	ALFAIDRO PPR PIPES AND FITTINGS
			SDR 11 S5	SDR 9 S4	SDR 7.4 S3.2	SDR 7,4 S3.2	SDR 6 S2.5	SDR 5 S2.0
Working Pressure at a constant 70 °C including 30 days per years	75	5	9.38	12.90	11.33	13.30	14.27	17.07
		10	9.08	12.60	10.95	13.00	13.79	15.20
		25	7.82	12.20	9.32	12.70	11.74	15.00
		45	6.77	12.00	8.08	12.50	10.18	14.40
	80	5	8.88	11.70	10.72	12.20	13.50	13.86
		10	8.46	11.40	10.16	12.00	12.80	13.06
		25	7.38	11.10	8.84	11.70	11.14	13.72
		42.5	6.49	10.90	7.77	11.50	9.79	10.17
	85	5	8.17	10.70	9.85	11.10	12.42	13.32
		10	7.82	10.40	9.42	10.90	11.87	12.22
		25	6.70	10.10	8.05	10.60	10.14	11.06
		37.5	6.07	10.00	7.29	10.50	9.18	9.88
	90	5	7.50	9.80	9.04	10.10	11.39	11.74
		10	7.19	9.50	8.69	9.90	10.94	12.12
		25	5.88	9.20	7.03	9.60	8.86	9.91
		35	5.39	9.10	6.48	9.50	8.16	8.86
Working Pressure at a constant 70 °C including 60 days per years	75	5	9.26	12.30	11.20	13.10	14.11	15.90
		10	8.90	12.10	10.77	12.80	13.57	14.50
		25	7.62	11.70	9.19	12.50	11.58	13.70
		45	6.60	11.50	7.97	12.30	10.05	12.80
	80	5	8.61	11.40	10.41	12.00	13.12	15.80
		10	8.24	11.20	9.96	11.70	12.54	15.40
		25	6.93	10.80	8.38	11.50	10.56	13.20
		40	6.18	10.70	7.47	11.30	9.41	11.60
	85	5	7.91	10.40	9.55	10.90	12.03	15.78
		10	7.56	10.20	9.14	10.50	11.52	15.30
		25	6.05	9.90	7.31	10.40	9.22	13.30
		35	5.57	9.80	6.73	10.30	8.48	11.20
	90	5	7.25	9.50	8.76	9.90	11.04	14.90
		10	6.40	9.30	7.75	9.70	9.76	12.90
		25	5.12	9.10	6.20	9.50	7.81	10.48
		30	4.90	9.00	5.92	9.40	7.46	8.45
Working Pressure at a constant 70 °C including 90 days per years	75	5	9.17	12.20	11.12	13.00	14.02	14.73
		10	8.79	12.00	10.62	12.70	13.38	13.80
		25	7.45	11.60	8.99	12.40	11.33	12.40
		45	6.45	11.40	7.80	12.20	9.82	11.20
	80	5	8.46	11.30	10.23	11.80	12.90	16.10
		10	8.11	11.00	9.80	11.60	12.35	15.50
		25	6.60	10.70	7.97	11.30	10.05	12.71
		37.5	5.98	10.60	7.21	11.20	9.09	11.52
	85	5	7.76	10.30	9.37	10.80	11.81	15.15
		10	7.03	10.10	8.51	10.60	10.72	14.20
		25	5.63	9.80	6.81	10.30	8.58	12.16
		32.5	5.28	9.70	6.37	10.20	8.03	11.40
	90	5	6.96	9.40	8.41	9.80	10.59	11.30
		10	5.88	9.20	7.11	9.60	8.96	10.45
		25	5.63	8.90	5.69	9.30	7.17	9.22



ALFAIDRO

DESIGN 4

Pipe sizing can be made through detailed calculation or simplified calculation.

In the table below are shown some of existing national detailed calculation methods; they can be used in cases where reasons for differentiated pipe sizing are given, e.g. for big buildings, industrial and commercial plants etc.

Table 4.1 - National pipe sizing methods

COUNTRY	Document n°	TITLE
Austria	ÖNORM B 2531 - 2	Trinkwasserversorgungseinrichtungen in Grundstücken; Bemessung der Rohrleitungen
Denmark	DS 439	Code of Practice for domestic water supply installations
Finland	National Building Code of Finland, D1	Water supply and drainage installations for buildings; Regulations and recommendations 1987
France	NF P40-202 (ref DTU 60.11)	Règles de calcul des installations de plomberie sanitaire et des installations d'évacuation des eaux pluviales
Germany	DIN 1988-3	Technische Regeln für Trinkwasser-Installationen (TRWI); Ermittlung der Rohrdurchmesser; Technische Regel des DVGW
The Netherlands	VEWIN Working Sheets WB2.1 WB 2.1 A WB 2.1 C WB 2.1 G	Principles of calculation: General and overview Principles of calculation: Flow rate and working pressures for tapware and apparatus Principles of calculation: Calculation and design criteria Principles of calculation and tables for determining pressure losses in pipes
Spain	Código Técnico de la edificación, Sección HS4 PNE 149201	Suministro de agua Abastecimiento de agua. Dimensionamiento de instalaciones interiores de agua
United Kingdom	BS 6700:1997	Specification for design, installation, testing and maintenance of services supplying water for domestic use within buildings and their curtilages
Italy	UNI 9182	Impianti di alimentazione e distribuzione d'acqua fredda e calda Progettazione, installazione e collaudo

In the following sections some technical knowledge and calculation examples for the detailed and simplified method according to **UNI 9182** and **UNI EN 806-3**, respectively, are given.

4.1 DIMENSIONING OF HOT AND COLD WATER PIPING SYSTEMS - DETAILED METHOD

To make a right pipeline dimensioning, it is necessary to know the maximum simultaneous flow, the maximum pressure and maximum admissible speed.

Maximum simultaneous flow

It is the value indicating the maximum contemporaneous flow of all the single uses served by a line for the whole busy period.

To calculate the maximum simultaneous flow it is used the method based on load units **(LU)** according to **UNI 9182**. The load unit is a conventional value representing the flow rate of a tap expressed according to the real flow, the dimensional and functional characteristics and the frequency of use.

The following tables show the LU values for the most common sanitary apparatus in a house and in public buildings:

Table 4.2 - LU for sanitary apparatus of private house

APPARATUS	LU		
	COLD WATER	HOT WATER	COLD WATER + HOT WATER
Wash basin	0.75	0.75	1.00
Bidet	0.75	0.75	1.00
WC with flush tank	3.00	-	3.00
WC with flowmeter	6.00	-	6.00
Bath tub	1.50	1.50	2.00
Shower bath	1.50	1.50	2.00
Kitchen sink	1.50	1.50	2.00
Washing machine	2.00	-	2.00
Dish washer	2.00	-	2.00
Laundry sink	1.50	1.50	2.00
Hydrant ø 3/8"	1.00	-	1.00
Hydrant ø 1/2"	2.00	-	2.00
Hydrant ø 3/4"	3.00	-	3.00
Hydrant ø 1"	6.00	-	6.00

Table 4.3 - LU for sanitary apparatus of public buildings

APPARATUS	LU		
	COLD WATER	HOT WATER	COLD WATER + HOT WATER
Wash basin	1.50	1.5	2.00
Bidet	1.50	1.5	2.00
WC with flush tank	5.00	-	5.00
WC with flowmeter	10.00	-	10.00
Bath tub	3.00	3.00	4.00
Shower bath	3.00	3.00	4.00
Kitchen sink	3.00	3.00	4.00
Hydrant ø 3/8"	2.00	-	2.00
Hydrant ø 1/2"	4.00	-	4.00
Hydrant ø 3/4"	6.00	-	6.00
Hydrant ø 1"	10.00	-	10.00

If more than one apparatus is installed, it is generally taken into account that not more than two are used simultaneously.

The following tables show the LU values for a combination of apparatus.

Table 4.4 - LU for combination of sanitary apparatus of private house

APPARATUS	LU		
	COLD WATER	HOT WATER	COLD WATER + HOT WATER
COMPLETE BATHROOM: wash basin + bidet + bath tub (or shower bath) + WC with flush tank	4.50	2.25	5.00
COMPLETE BATHROOM: wash basin + bidet + bath tub (or shower bath) + WC with flowmeter	7.50	2.25	8.00
COMPLETE BATHROOM: WC with flush tank + washing machine	5.50	2.25	6.00
COMPLETE BATHROOM: WC with flowmeter + washing machine	8.50	2.25	9.00
SERVICE BATHROOM: wash basin + WC with flush tank	3.00	0.75	3.00
SERVICE BATHROOM: wash basin + WC with flowmeter	6.00	0.75	6.00
SERVICE BATHROOM: WC with flush tank + washing machine	4.00	0.75	4.50
SERVICE BATHROOM: WC with flowmeter + washing machine	7.00	0.75	7.00
COMPLETE BATHROOM: WC with flush tank + kitchen (sink and dish washer)	6.00	3.50	7.00
COMPLETE BATHROOM: WC with flowmeter + kitchen (sink and dish washer)	8.50	3.25	10.00

Table 4.5 - LU for combination of sanitary apparatus of public buildings

APPARATUS	LU		
	COLD WATER	HOT WATER	COLD WATER + HOT WATER
BATHROOM FOR HOTEL: WC with flush tank	6.00	3.50	7.00
BATHROOM FOR HOTEL: WC with flowmeter	10.00	3.50	12.00
COMPLETE BATHROOM FOR HOSPITAL OR CLINIC : WC with flush tank	5.00	3.00	5.00
COMPLETE BATHROOM FOR HOSPITAL OR CLINIC : WC with flowmeter	10.00	3.00	10.00

The LU value is assigned to every apparatus in the system and all the values are added; then using the tables and graphs below, the maximum simultaneous flow can be worked out.

Table 4.6 - Maximum simultaneous flow according to LU for private house and WC with flush tank

LU UC	Flow rate l/s	LU UC	Flow rate l/s	LU UC	Flow rate l/s
6	0.30	100	3.15	1250	15.50
8	0.40	120	3.65	1500	17.50
10	0.50	140	3.90	1750	18.80
12	0.60	160	4.25	2000	20.50
14	0.68	180	4.60	2250	22.00
16	0.78	200	4.95	2500	23.50
18	0.85	225	5.35	2750	24.50
20	0.93	250	5.75	3000	26.00
25	1.13	275	6.10	3500	28.00
30	1.30	300	6.45	4000	30.50
35	1.46	400	7.80	4500	32.50
40	1.62	500	9.00	5000	34.50
50	1.90	600	10.00	6000	38.00
60	2.20	700	11.00	7000	41.00
70	2.40	800	11.90	8000	44.00
80	2.65	900	12.90	9000	47.00
90	2.90	1000	13.80	10000	50.00

Table 4.7 Maximum simultaneous flow according to LU for private house for WC with flowmeter

LU UC	Flow rate l/s	LU UC	Flow rate l/s	LU UC	Flow rate l/s
10	1.70	120	7.15	1250	21.00
12	1.90	140	7.50	1500	23.00
14	2.10	160	8.00	1750	24.50
16	2.27	180	8.50	2000	26.00
18	2.45	200	9.00	2250	27.50
20	2.60	225	9.50	2500	28.50
25	2.95	250	10.00	2750	29.50
30	3.25	275	10.50	3000	30.50
35	3.55	300	11.00	3500	33.00
40	3.80	400	12.70	4000	35.50
50	4.30	500	14.00	4500	36.50
60	4.80	600	15.10	5000	37.50
70	5.25	700	16.30	6000	40.50
80	5.60	800	17.30	7000	41.00
90	6.00	900	18.20	8000	44.00
100	6.35	1000	19.00	9000	48.00
-	-	-	-	10000	50.00

Table 4.8 Maximum simultaneous flow according to LU for public buildings for WC with flush tank

LU UC	Flow rate l/s	LU UC	Flow rate l/s	LU UC	Flow rate l/s
10	0.50	160	3.50	1750	13.60
12	0.60	180	3.75	2000	14.50
14	0.67	200	3.95	2250	15.40
16	0.75	225	4.25	2500	16.20
18	0.82	250	4.50	2750	17.00
20	0.89	275	4.80	3000	18.00
25	1.05	300	5.05	3500	19.50
30	1.18	400	6.00	4000	21.00
35	1.35	500	6.90	4500	22.00
40	1.45	600	7.55	5000	23.50
50	1.65	700	8.30	6000	25.50
60	1.90	800	8.80	7000	27.50
70	2.10	900	9.50	8000	29.00
80	2.25	1000	10.00	9000	30.50
90	2.45	-	-	10000	32.00
100	2.60	-	-	-	-

Table 4.9 Maximum simultaneous flow according to LU for public buildings for WC with flowmeter

LU UC	Flow rate l/s	LU UC	Flow rate l/s	LU UC	Flow rate l/s
10	1.70	120	5.80	1250	15.5
12	1.87	140	6.20	1500	16.5
14	2.03	160	6.60	1750	17.5
16	2.17	180	7.10	2000	18.5
18	2.32	200	7.45	2250	19.2
20	2.45	225	7.80	2500	20.0
25	2.75	250	8.10	2750	20.7
30	3.00	275	8.40	3000	21.4
35	3.25	300	8.70	3500	22.5
40	3.55	400	9.80	4000	24.0
50	3.90	500	10.80	4500	25.0
60	4.20	600	11.60	5000	26.2
70	4.50	700	12.40	6000	28.0
80	4.80	800	13.0	7000	29.0
90	5.15	900	13.7	8000	30.0
100	5.35	1000	14.2	9000	31.5
100	-	-	-	10000	32.0

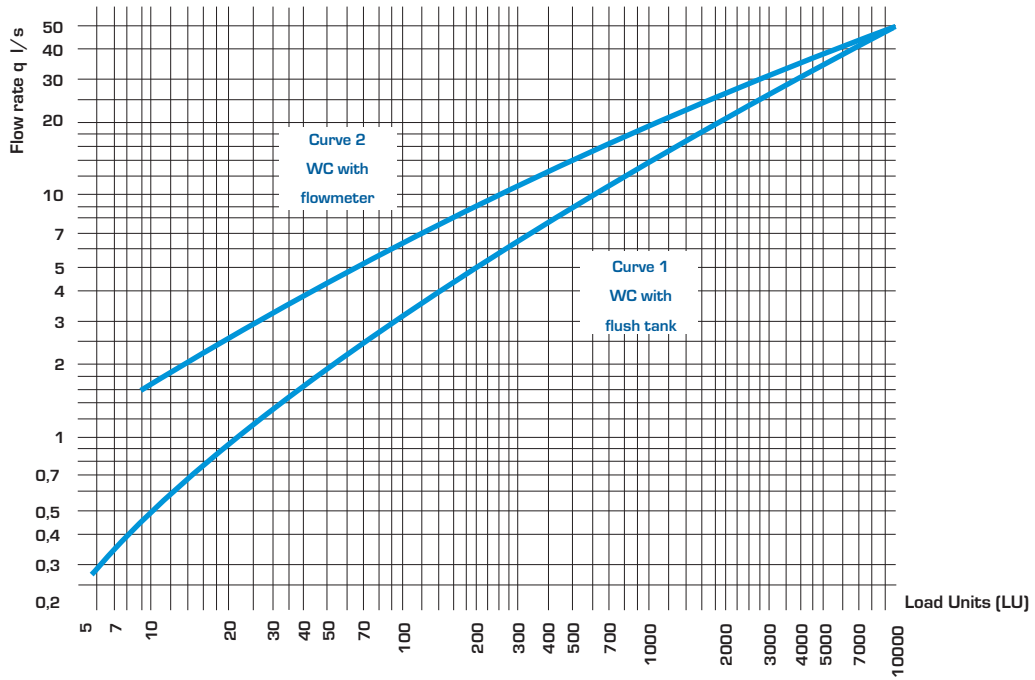

Figure 4.1 - Curves $q=f$ (LU): flow rate according to LU for private house (UNI 9182)

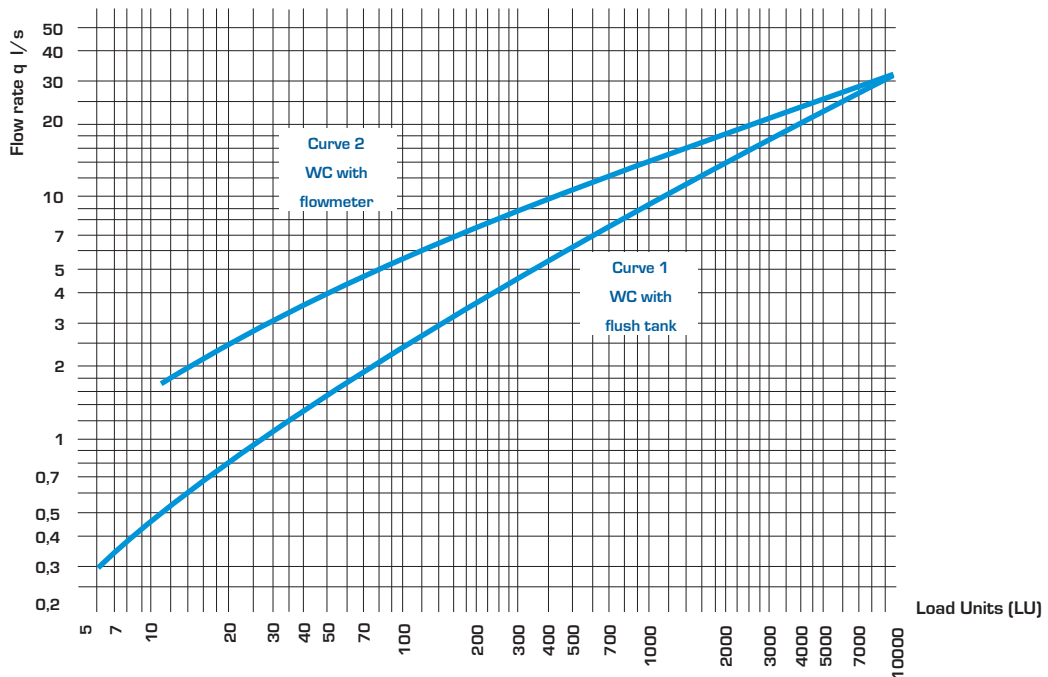

Figure 4.2 - Curves $q=f$ (LU): flow rate according to LU for public buildings (UNI 9182)

EXAMPLE

- consider a riser supplying hot and cold water to 5 complete bathrooms of a **private house** with WC with flowmeters: the LU value for combination of apparatus is equal to 8 (table 4.5) for a total of $5 \times 8 = 40$ LU on the riser; the corresponding flow is worked out from table 4.7 and is equal to 3.8 l/s.

- consider a riser supplying cold water to 40 flats equipped with complete bathroom (WC with flowmeter) and kitchen: from table 4.5 we obtain 8,5 LU for each flat for a total of 340 unit loads; the corresponding flow rate is obtained from the diagram above and is equal to 11,9 l/s.

After determining the maximum simultaneous flow and knowing the value of available head, it is possible to calculate the pipe diameter as described below.

■ Calculus of the pipes diameter

It is carried out in two steps: preliminary calculus and verification calculus.

a) **In preliminary calculus**, it is considered the line joining the tank (delivery system by fall) or the aqueduct (delivery system by pump) to a tap located in the most unfavourable position; this line is divided into sections with constant flow and the diameter is calculated according to the flow rate and the speed assigned in advance:

$$d = \sqrt{\frac{q \cdot 4}{v \cdot 3.14}} \cdot 1000$$

wherein:

- d pipe inside diameter in mm;
- q flow in m³/s;
- v average speed of flow in m/s.

The pipe flow rate is worked out using the method described at point 4.1, while the speed can be worked out from table 4.10 and it is assigned on the grounds of:

- 1) difference of level between the tank and the tap, in case of distribution by tank;
- 2) difference of aqueduct pressure and the difference of level between it and the tap, in case of pressure distribution.

Table 4.10 - Maximum admissible flow speed

Values of the difference of level between the tank and the tap (or values of the difference of aqueduct pressure and the difference of level between it and the tap) m	Flow speed m/s
1 - 4	0.50 - 0.60
4 - 10	0.60 - 1.00
10 - 20	1.00 - 1.50
20 or more	1.50 - 2.00

EXAMPLE

Consider a pipe with maximum simultaneous flow of 3 l/s to which we assign a maximum speed of 1,1 m/s:

the internal diameter will be equal to:

$$d = \sqrt{\frac{3 \cdot 10^{-3} \cdot 4}{1.1 \cdot 3.14}} \cdot 1000 = 58,94 \text{ mm}$$

The commercial diameter is 63 mm.

N.B. For bathrooms and kitchens dimensioning is not necessary to use formulas, usually ø 20 pipes are used except for flowmeter apparatus joined by ø 25 and 32 pipes directly to the riser.

b) In verification calculus, once the pressure losses and the pressure occurring at the section ends are quantified, it is verified that the following conditions exist.

1) For tank supplying systems, the sum of:

- pressure upstream of the most unfavourable tap, p_1
- distributed pressure losses, J_d ;
- localized pressure losses, ΣJ_l

has to be equal or less than the difference of level between the tank bottom and the most unfavourably located tap:

$$Z_o \geq p_1 + J_d + \Sigma J_l$$

2) For systems under pressure, the sum of:

- pressure upstream of the most unfavourably located tap, p_1 ;
- distributed pressure losses, J_d ;
- localized pressure losses, ΣJ_l

has to be equal to or less than the minimum pressure value of the aqueduct:

$$p_o \geq p_1 + Z_1 + J_d + \Sigma J_l$$

If the values mentioned above are respected, the preliminary calculus is correct; on the contrary, the diameter has to be decreased or increased.

The section length value (l) and the difference of level between the tap and the tank/aqueduct (Z) are obtained from the system scheme designed in advance, while the section flow rate values are calculated using the method described at 4.1.1. Distributed (J_d) and localized (ΣJ_l) pressure losses are quantified using the following method:

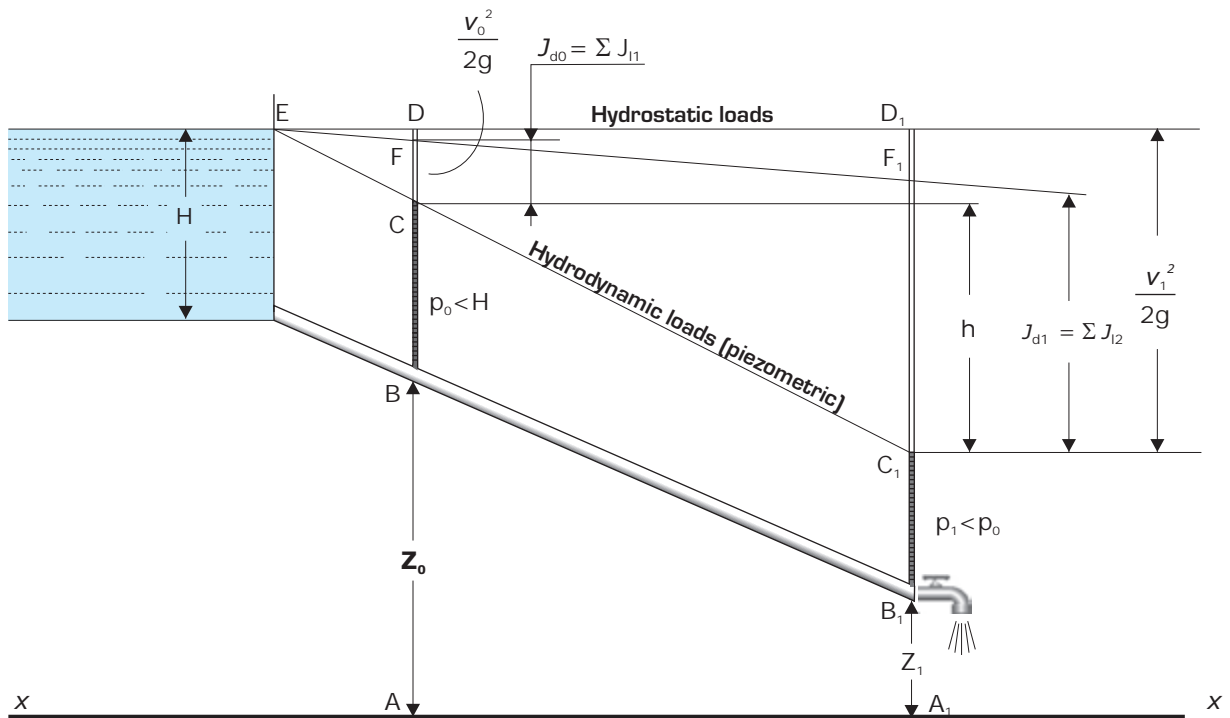

Fig. 4.3 Hydrostatic and hydrodynamic loads

H = height of water in the tank; h = hydrodynamic pressure loss = $\frac{v_1^2}{2g} - \frac{v_0^2}{2g}$

4.2 DIMENSIONING OF HOT AND COLD WATER SYSTEMS - SIMPLIFIED METHOD

The standard **UNI EN 806-3** provides a simplified method for the dimensioning of the pipelines for standard-installation. This method can be used for all type of buildings, which do not have measurements, highly exceeding the average.

That means that in most of the buildings the simplified method can be applied. This method is equally used for cold and for hot water pipes.

N.B: As hot water return pipes have to fulfil other hydraulic requirements, they cannot be sized with this method, pipe sizing takes into consideration the pressure.

■ Characteristics of installations

An installation can be called a standard-installation, when:

- the draw off flow rates do not exceed those set out in Table 4.11
- the kind of demand does not exceed the design flow-rate;
- it is not designed for continuous use of water, continuous use being defined as use lasting more than 15 min.

■ Pressure conditions

- Static pressure at draw off point: max. 500 kPa (Exception: garden/ garage taps max. 1 000 kPa);
- flow pressure at draw off point: min. 100 kPa.

Several draw off points, e.g. thermostatic mixing valves, need a higher flow pressure. Calculations have to consider this matter.

The difference between the static pressure at the lowest draw off point and the flow pressure at the hydraulic worstcase draw off point, reduced by the pressure losses [see section 4.2], give the possible head of difference in elevation within a pressure section.

■ Maximum flow velocities

- Header pipes, rising pipes, floor service pipes: max. 2,0 m/s;
- connection pipes to one fitting (dead legs): max. 4,0 m/s.

NOTE: National regulations may require lower flow velocities to avoid water hammer and noise.

■ Loading unit (LU)

1 LU is equivalent to a draw-off flow rate of 0,1 l/s.

Table 4.11 - Draw-Off Flow-rates, minimum flow-rates at draw-off points and LU for D= points LU for combination of sanitary apparatus of private house

DRAW - Off Point	Draw-off flow Rate (l/s)	Minimum Flow-Rates at draw-Off points (l/S)	LU
Wash basin , Hand basin, WC-Cistern, Bidet	0.1	0.1	1
Domestic kitchen sink, Washing machine, Dish washer, Shower bat	0.2	0.15	2
Urinal flush valve	0.3	0.15	3
Domestic bath tub	0.4	0.3	4
Hydrant for garden/ garage	0.5	0.4	5
Non domestic kitchen sink DN20, non domestic domestic bath tub	0.8	0.8	8
Flush valve DN20	1.5	1.0	15

The values in this Table do not correspond with the values in product norms. They are only used for pipe sizing.

Application of the simplified method

Beginning at the last draw-off point, the LU for each section of the installation have to be determined. The LU must be added. The probability of simultaneous demand has been taken into consideration in Tables 4.12.

Table 4.12 - LU for determination of pipe diameter

Max. load	LU	1	2	3	3	4	6	13	30	70	200	540	970	
Highest value for simultaneous demand	LU			2			4	5	8					
DN x s	mm	16 x 2,7		20 x 3,4			25 x 4,2		32 x 5,4		40 x 6,7		50 x 8,4	
d _i	mm	10.6		13.2			16.6		21.2		26.6		33.2	
Max lenght of pipe	m	20	12	8	15	9	7							

Example for the determination of pipe sizes for standard-installations

Beginning at the end of the pipe, the loading units must be added. Resulting from this calculation the size of that part of the pipe can be determined. The cold water pipe from the under ground floor to the draw-off points has to be sized.

In every apartment the following draw-off points will be installed:

- 1 domestic bath
- 1 WC-cistern
- 1 washbasin
- 1 domestic kitchen sink

There are five equal apartments.

Find the loading units from Table 4.12:

- 1 Domestic bath tub 4 LU
- 1 WC-cistern 1 LU
- 1 washbasin 1 LU
- 1 domestic kitchen sink 2 LU

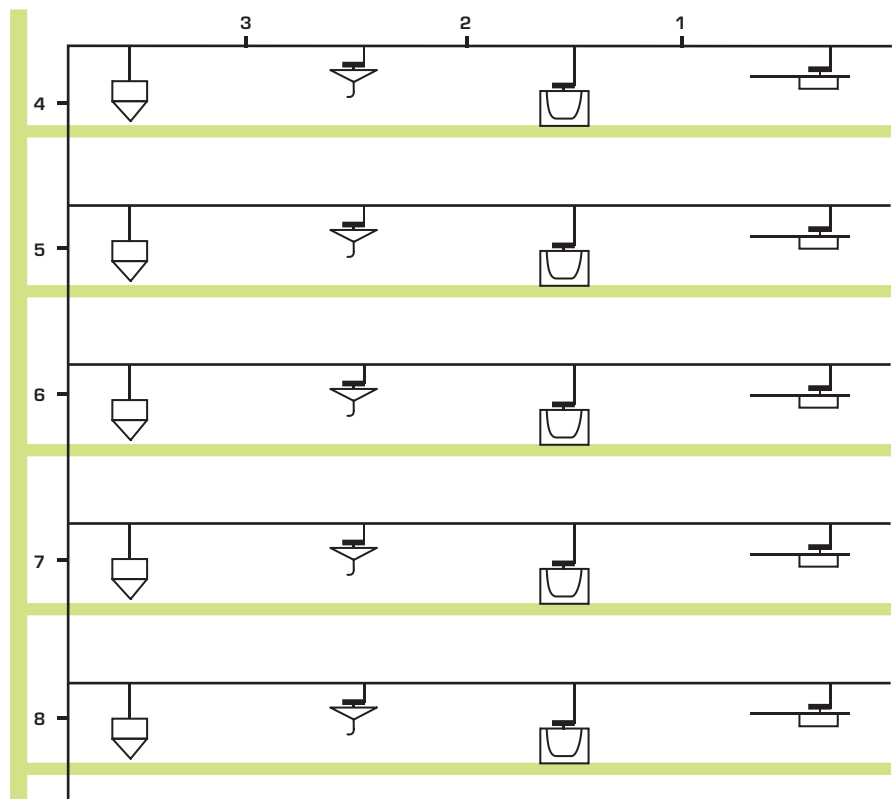

<p>PART 1</p> <p>connected is 1 domestic kitchen sink = 2 LU Table 4.12: demands for 2 LU = DN 16</p>	<p>PART 2</p> <p>connected are 1 domestic kitchen sink = 2 LU 1 domestic bath = 4 LU total = 6 LU Table 4.12: demands for 6 LU = DN 20</p>	<p>PART 3</p> <p>connected are 1 domestic kitchen sink = 2 LU 1 domestic bath = 4 LU 1 washbasin = 1 LU total = 7 LU Table 4.12: demands for 7 LU = DN 20</p>	<p>PART 4</p> <p>connected are 1 domestic kitchen sink = 2 LU 1 domestic bath = 4 LU 1 washbasin = 1 LU 1 WC-cistern = 1 LU total per apartment = 8 LU Table 4.12: demands for 8 LU = DN 20</p>
<p>PART 5</p> <p>connected are 2 apartments = 16 LU Table 4.12: demands for 16 LU = DN 25</p>	<p>PART 6</p> <p>connected are 3 apartments = 24 LU Table 4.12: demands for 24 LU = DN 32</p>	<p>PART 7</p> <p>connected are 4 apartments = 32 LU Table 4.12: demands for 32 LU = DN 32</p>	<p>PART 8</p> <p>connected are 5 apartments = 40 LU Table 4.12: demands for 40 LU = DN 40</p>

4.3 PRESSURE LOSSES

For the piping system layout, pressure losses have to be known since they influence the flow and then the quantity of water arriving to the separate uses in a unit of time.

The pressure produced by the water motion is never exploited entirely since part of it is lost to win the resistance that the water meets in motion.

The pressure losses can be distributed or localised and they are respectively due to:

- continuous resistance, induced by the water friction against the walls of the pipeline and by the friction inside the flow itself, due to viscosity;
- accidental resistance, induced by the water impact against the transversal and slanting walls as to the direction of its motion.

The most common are:

- water flowing through mouthpieces (fittings);
- change in the direction and section of the pipes (elbows, tees, reducers, etc.);
- water flowing through stop and output cocks.

4.3.1 DISTRIBUTED PRESSURE LOSSES

Pressure loss for continuous resistance is proportional to the surface wetted by water, to the specific weight of water, to the mean flow speed and to the pipeline walls roughness: it can be worked out using Blasius's formula:

$$J_d = \frac{\lambda v^2}{2g d_i} 10^6$$

wherein:

- J_d pipe distributed pressure loss, in mm/m;
- v water flow speed, in m/s;
- g acceleration of gravity equal to 9,81 m/s²;
- d_i pipe inside diameter, in mm;
- λ pressure loss coefficient according to Reynolds no. (Re) and the material surface roughness (ϵ).

The Reynolds number is worked out by the following formula:

$$Re = \frac{\rho v d_i}{\mu}$$

wherein:

- ρ water density equal to 998 kg/m³ at 20 °C and 983.2 kg/m³ at 60 °C;
- μ water viscosity equal to 1.018 10⁻³ kg/m at 20 °C and 0.462 10⁻³ kg/m at 60 °C.

Alfaidro, **Alfaidro FASER** and **Alfaidro ALUMINIUM** pipes have a very low surface roughness ($\epsilon=0,007$ mm) and, consequently, pressure losses are very low compared to traditional pipes.

Note

The calculation of λ depends on the type of flow (laminar or turbulent) inside the pipes; the following graphs and tables are useful to work out the distributed pressure losses at 20 °C and 60 °C.

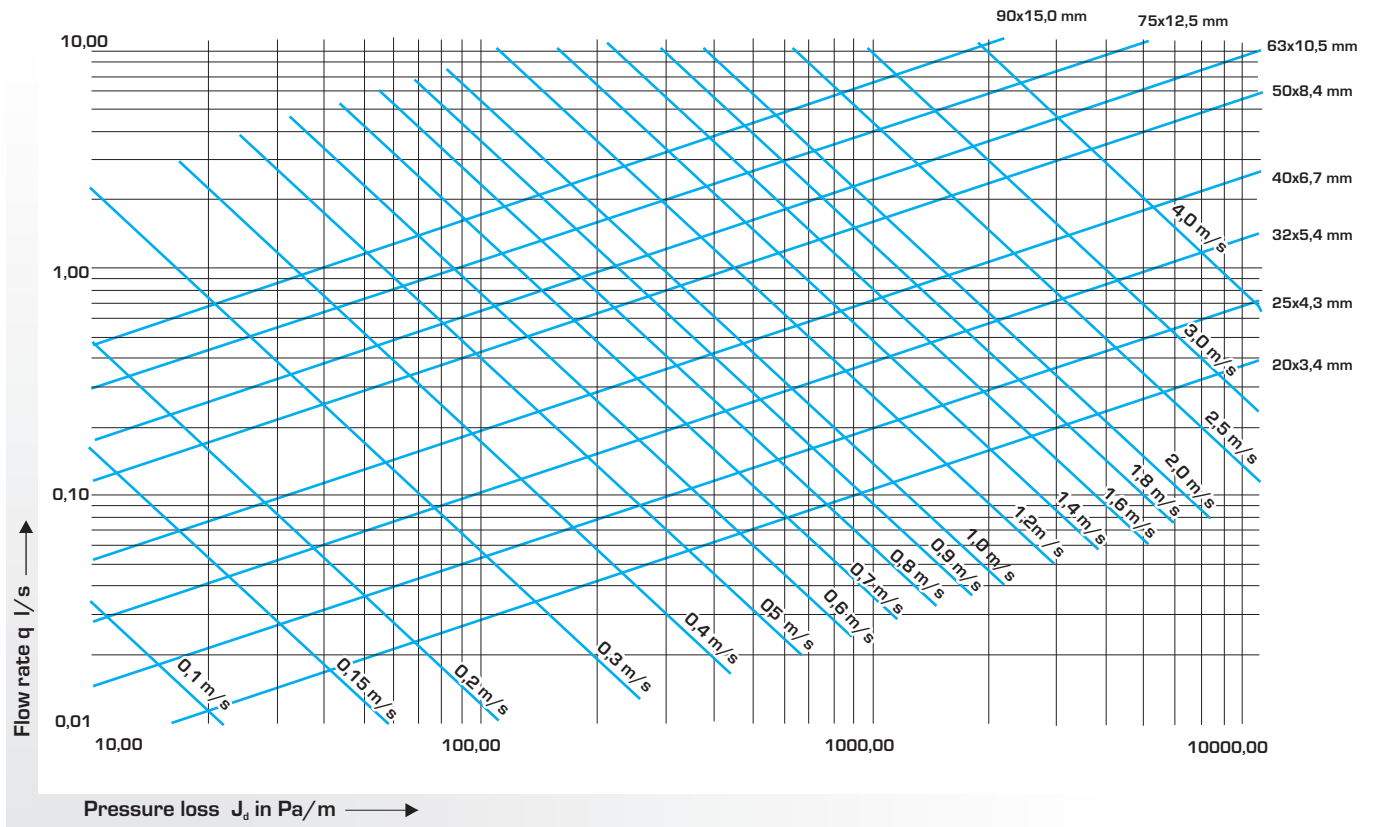

Figure 4.4 - Diagram of distributed pressure losses in SDR 6 Alfaidro pipes at 20°C

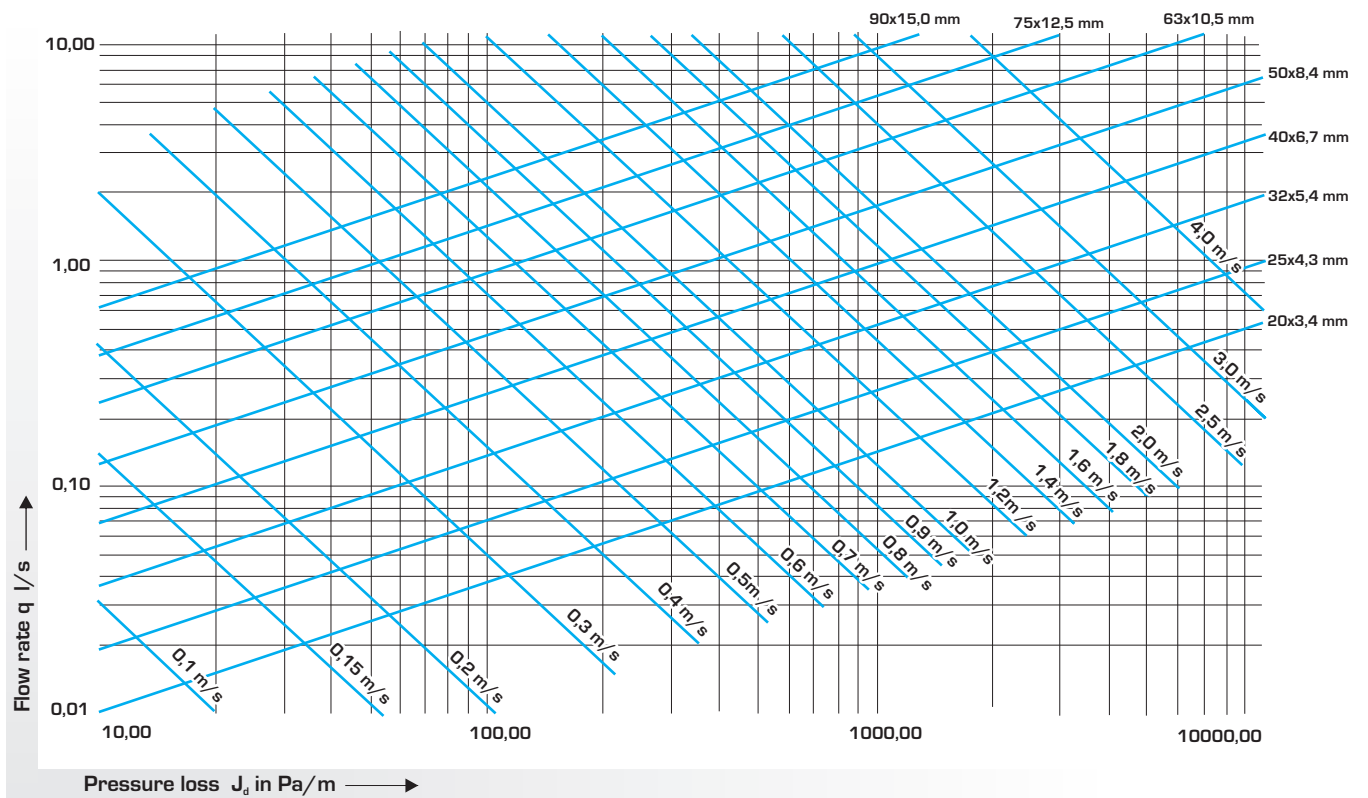

Figure 4.5 - Diagram of distributed pressure losses in SDR 6 Alfaidro pipes at 60°C

Table 4.13 - Distributed pressure losses values in SDR 11 Alfaidro pipes at 20°C

SDR 11 20 °C	Nominal diameter (mm)																
	32	40	50	63	75	90	110	125	140	160	180	200	225	250	280	315	
	Wall thickness (mm)																
	2,9	3,7	4,6	5,8	6,8	8,2	10,0	11,4	12,7	14,6	16,4	18,2	20,5	22,7	25,4	28,6	
Inside diameter (mm)																	
26,2 32,6 40,8 51,4 61,4 73,6 90,0 102,2 114,6 130,8 147,2 163,6 184,0 204,6 229,2 257,8																	
			$\varepsilon = 0,007 \text{ mm}$					$\rho = 998 \text{ kg/m}^3$					$\mu = 1,018 \times 10^{-3} \text{ kg/m s}$				
q	q = Flow rate (l/sec)					V = Speed (m/s)					J = Pressure loss (mm/m)						
0,06	V	0,11	-	-	-	-	-	-	-	-	-	-	-	-	-	-	
	J	1,04	-	-	-	-	-	-	-	-	-	-	-	-	-	-	
0,07	V	0,13	-	-	-	-	-	-	-	-	-	-	-	-	-	-	
	J	1,36	-	-	-	-	-	-	-	-	-	-	-	-	-	-	
0,08	V	0,15	0,10	-	-	-	-	-	-	-	-	-	-	-	-	-	
	J	1,72	0,61	-	-	-	-	-	-	-	-	-	-	-	-	-	
0,09	V	0,17	0,11	-	-	-	-	-	-	-	-	-	-	-	-	-	
	J	2,11	0,75	-	-	-	-	-	-	-	-	-	-	-	-	-	
0,10	V	0,19	0,12	-	-	-	-	-	-	-	-	-	-	-	-	-	
	J	2,54	0,90	-	-	-	-	-	-	-	-	-	-	-	-	-	
0,12	V	0,22	0,14	-	-	-	-	-	-	-	-	-	-	-	-	-	
	J	3,49	1,24	-	-	-	-	-	-	-	-	-	-	-	-	-	
0,14	V	0,26	0,17	0,11	-	-	-	-	-	-	-	-	-	-	-	-	
	J	4,57	1,62	0,56	-	-	-	-	-	-	-	-	-	-	-	-	
0,16	V	0,30	0,19	0,12	-	-	-	-	-	-	-	-	-	-	-	-	
	J	5,77	2,04	0,70	-	-	-	-	-	-	-	-	-	-	-	-	
0,18	V	0,33	0,22	0,14	-	-	-	-	-	-	-	-	-	-	-	-	
	J	7,10	2,51	0,87	-	-	-	-	-	-	-	-	-	-	-	-	
0,20	V	0,37	0,24	0,15	0,10	-	-	-	-	-	-	-	-	-	-	-	
	J	8,53	3,02	1,04	0,35	-	-	-	-	-	-	-	-	-	-	-	
0,30	V	0,56	0,36	0,23	0,14	0,10	-	-	-	-	-	-	-	-	-	-	
	J	17,35	6,14	2,12	0,71	0,30	-	-	-	-	-	-	-	-	-	-	
0,40	V	0,74	0,48	0,31	0,19	0,14	-	-	-	-	-	-	-	-	-	-	
	J	28,70	10,16	3,50	1,17	0,50	-	-	-	-	-	-	-	-	-	-	
0,50	V	0,93	0,60	0,38	0,24	0,17	0,12	-	-	-	-	-	-	-	-	-	
	J	42,41	15,02	5,17	1,73	0,74	0,31	-	-	-	-	-	-	-	-	-	
0,60	V	1,11	0,72	0,46	0,29	0,20	0,14	-	-	-	-	-	-	-	-	-	
	J	58,35	20,66	7,12	2,38	1,02	0,43	-	-	-	-	-	-	-	-	-	
0,70	V	1,30	0,84	0,54	0,34	0,24	0,16	0,11	-	-	-	-	-	-	-	-	
	J	76,41	27,06	9,32	3,11	1,34	0,57	0,22	-	-	-	-	-	-	-	-	
0,80	V	1,48	0,96	0,61	0,39	0,27	0,19	0,13	0,10	-	-	-	-	-	-	-	
	J	96,53	34,18	11,77	3,93	1,69	0,71	0,27	0,15	-	-	-	-	-	-	-	
0,90	V	1,67	1,08	0,69	0,43	0,30	0,21	0,14	0,11	-	-	-	-	-	-	-	
	J	118,6	42,01	14,47	4,83	2,08	0,88	0,34	0,18	-	-	-	-	-	-	-	
1,00	V	1,86	1,20	0,77	0,48	0,34	0,24	0,16	0,12	0,10	-	-	-	-	-	-	
	J	142,6	50,51	17,40	5,81	2,50	1,06	0,41	0,22	0,13	-	-	-	-	-	-	
1,20	V	2,23	1,44	0,92	0,58	0,41	0,28	0,19	0,15	0,12	-	-	-	-	-	-	
	J	196,2	69,50	23,94	7,99	3,44	1,45	0,56	0,31	0,18	-	-	-	-	-	-	
1,40	V	2,60	1,68	1,07	0,68	0,47	0,33	0,22	0,17	0,14	0,10	-	-	-	-	-	
	J	257,0	91,02	31,35	10,47	4,50	1,90	0,73	0,40	0,23	0,12	-	-	-	-	-	
1,60	V	2,97	1,92	1,22	0,77	0,54	0,38	0,25	0,20	0,16	0,12	-	-	-	-	-	
	J	324,6	114,9	39,61	13,22	5,68	2,40	0,92	0,51	0,29	0,16	-	-	-	-	-	
1,80	V	3,34	2,16	1,38	0,87	0,61	0,42	0,28	0,22	0,17	0,13	0,11	-	-	-	-	
	J	399,0	141,3	48,67	16,25	6,98	2,95	1,14	0,62	0,36	0,19	0,11	-	-	-	-	
2,00	V	3,71	2,40	1,53	0,96	0,68	0,47	0,31	0,24	0,19	0,15	0,12	0,10	-	-	-	
	J	479,7	169,9	58,53	19,54	8,40	3,55	1,37	0,75	0,43	0,23	0,13	0,08	-	-	-	
2,20	V	4,08	2,64	1,68	1,06	0,74	0,52	0,35	0,27	0,21	0,16	0,13	0,10	-	-	-	
	J	614,1	200,7	69,15	23,09	9,92	4,20	1,61	0,88	0,51	0,27	0,16	0,09	-	-	-	
2,40	V	4,45	2,88	1,84	1,16	0,81	0,56	0,38	0,29	0,23	0,18	0,14	0,11	-	-	-	
	J	716,0	233,7	80,52	26,88	11,55	4,89	1,88	1,03	0,60	0,32	0,18	0,11	-	-	-	
2,60	V	4,83	3,12	1,99	1,25	0,88	0,61	0,41	0,32	0,25	0,19	0,15	0,12	0,10	-	-	
	J	825,6	296,2	92,63	30,93	13,29	5,62	2,16	1,18	0,69	0,37	0,21	0,13	0,07	-	-	
2,80	V	5,20	3,36	2,14	1,35	0,95	0,66	0,44	0,34	0,27	0,21	0,16	0,13	0,11	-	-	
	J	943,1	335,9	105,4	35,21	15,13	6,40	2,46	1,35	0,78	0,42	0,24	0,14	0,08	-	-	
3,00	V	-	3,60	2,30	1,45	1,01	0,71	0,47	0,37	0,29	0,22	0,18	0,14	0,11	-	-	
	J	-	378,2	118,9	39,73	17,07	7,22	2,78	1,52	0,88	0,47	0,27	0,16	0,09	-	-	
3,20	V	-	3,84	2,45	1,54	1,08	0,75	0,50	0,39	0,31	0,24	0,19	0,15	0,12	0,10	-	
	J	-	423,0	133,2	44,48	19,12	8,08	3,11	1,70	0,99	0,53	0,30	0,18	0,10	0,06	-	
3,40	V	-	4,08	2,60	1,64	1,15	0,80	0,53	0,41	0,33	0,25	0,20	0,16	0,13	0,10	-	
	J	-	470,2	167,4	49,45	21,26	8,99	3,46	1,89	1,10	0,59	0,33	0,20	0,12	0,07	-	
3,60	V	-	4,32	2,75	1,74	1,22	0,85	0,57	0,44	0,35	0,27	0,21	0,17	0,14	0,11	-	
	J	-	520,0	184,0	54,66	23,49	9,93	3,82	2,09	1,21	0,65	0,37	0,22	0,13	0,08	-	
3,80	V	-	4,55	2,91	1,83	1,28	0,89	0,60	0,46	0,37	0,28	0,22	0,18	0,14	0,12	-	
	J	-	572,2	201,3	60,08	25,82	10,92	4,20	2,30	1,33	0,71	0,41	0,25	0,14	0,08	-	
4,00	V	-	4,79	3,06	1,93	1,35	0,94	0,63	0,49	0,39	0,30	0,24	0,19	0,15	0,12	0,10	
	J	-	627,0	219,4	65,72	28,25	11,94	4,59	2,51	1,46	0,78	0,44	0,27	0,15	0,09	0,05	
4,20	V	-	5,03	3,21	2,03	1,42	0,99	0,66	0,51	0,41	0,31	0,25	0,20	0,16	0,13	0,10	
	J	-	684,3	238,3	85,04	30,77	13,01	5,00	2,74	1,59	0,85	0,45	0,29	0,17	0,10	0,06	
4,40	V	-	-	3,37	2,12	1,49	1,03	0,69	0,54	0,43	0,33	0,26	0,21	0,17	0,13	0,11	
	J	-	-	257,9	91,47	33,38	14,11	5,43	2,97	1,72	0,92	0,52	0,32	0,18	0,11	0,06	

Table 4.13 - Distributed pressure losses values in SDR 11 Alfaidro pipes at 20°C

SDR 11 20 °C	Nominal diameter (mm)															
	32	40	50	63	75	90	110	125	140	160	180	200	225	250	280	315
	Wall thickness (mm)															
	2,9	3,7	4,6	5,8	6,8	8,2	10,0	11,4	12,7	14,6	16,4	18,2	20,5	22,7	25,4	28,6
	Inside diameter (mm)															
	26,2	32,6	40,8	51,4	61,4	73,6	90,0	102,2	114,6	130,8	147,2	163,6	184,0	204,6	229,2	257,8

$\epsilon = 0,007 \text{ mm}$

$\rho = 998 \text{ kg/m}^3$

$\mu = 1,018 \times 10^{-3} \text{ kg/m s}$

q	q = Flow rate (l/sec)			V = Speed (m/s)						J = Pressure loss (mm/m)						
4,60	V	-	-	3,52	2,22	1,55	1,08	0,72	0,56	0,45	0,34	0,27	0,22	0,17	0,14	0,11
	J	-	-	278,39	98,14	36,08	15,25	5,87	3,21	1,86	0,99	0,57	0,34	0,20	0,12	0,07
4,80	V	-	-	3,67	2,31	1,62	1,13	0,75	0,59	0,47	0,36	0,28	0,23	0,18	0,15	0,12
	J	-	-	299,60	105,04	38,86	16,43	6,32	3,46	2,01	1,07	0,61	0,37	0,21	0,13	0,07
5,00	V	-	-	3,83	2,41	1,69	1,18	0,79	0,61	0,48	0,37	0,29	0,24	0,19	0,15	0,12
	J	-	-	321,59	112,17	52,15	17,65	6,79	3,71	2,15	1,15	0,66	0,40	0,23	0,14	0,08
5,20	V	-	-	3,98	2,51	1,76	1,22	0,82	0,63	0,50	0,39	0,31	0,25	0,20	0,16	0,13
	J	-	-	344,36	119,54	55,31	18,90	7,27	3,97	2,31	1,23	0,70	0,43	0,24	0,15	0,09
5,40	V	-	-	4,13	2,60	1,82	1,27	0,85	0,66	0,52	0,40	0,32	0,26	0,20	0,16	0,13
	J	-	-	367,90	127,14	58,57	20,19	7,77	4,25	2,46	1,32	0,75	0,45	0,26	0,16	0,09
5,60	V	-	-	4,29	2,70	1,89	1,32	0,88	0,68	0,54	0,42	0,33	0,27	0,21	0,17	0,14
	J	-	-	392,23	134,98	61,92	21,52	8,28	4,53	2,63	1,40	0,80	0,48	0,28	0,17	0,10
5,80	V	-	-	4,44	2,80	1,96	1,36	0,91	0,71	0,56	0,43	0,34	0,28	0,22	0,18	0,14
	J	-	-	417,33	143,05	65,36	30,80	8,80	4,81	2,79	1,49	0,85	0,51	0,29	0,18	0,10
6,00	V	-	-	4,59	2,89	2,03	1,41	0,94	0,73	0,58	0,45	0,35	0,29	0,23	0,18	0,15
	J	-	-	443,21	151,36	68,90	32,32	9,34	5,11	2,96	1,58	0,90	0,55	0,31	0,19	0,11
6,20	V	-	-	4,74	2,99	2,10	1,46	0,98	0,76	0,60	0,46	0,36	0,30	0,23	0,19	0,15
	J	-	-	469,87	159,90	72,52	33,87	9,89	5,41	3,14	1,67	0,96	0,58	0,33	0,20	0,12
6,40	V	-	-	4,90	3,09	2,16	1,51	1,01	0,78	0,62	0,48	0,38	0,30	0,24	0,19	0,16
	J	-	-	497,31	168,67	76,25	35,45	10,46	5,72	3,32	1,77	1,01	0,61	0,35	0,21	0,12
6,60	V	-	-	5,05	3,18	2,23	1,55	1,04	0,80	0,64	0,49	0,39	0,31	0,25	0,20	0,16
	J	-	-	525,53	177,68	80,06	37,08	11,03	6,03	3,50	1,87	1,07	0,65	0,37	0,22	0,13
6,80	V	-	-	-	3,28	2,30	1,60	1,07	0,83	0,66	0,51	0,40	0,32	0,26	0,21	0,16
	J	-	-	-	186,93	83,97	38,74	11,63	6,36	3,69	1,97	1,12	0,68	0,39	0,24	0,14
7,00	V	-	-	-	3,38	2,37	1,65	1,10	0,85	0,68	0,52	0,41	0,33	0,26	0,21	0,17
	J	-	-	-	196,41	87,97	40,43	12,23	6,69	3,88	2,07	1,18	0,72	0,41	0,25	0,14
7,50	V	-	-	-	3,62	2,53	1,76	1,18	0,91	0,73	0,56	0,44	0,36	0,28	0,23	0,18
	J	-	-	-	221,13	98,38	44,83	19,86	7,54	4,38	2,34	1,33	0,81	0,46	0,28	0,16
8,00	V	-	-	-	3,86	2,70	1,88	1,26	0,98	0,78	0,60	0,47	0,38	0,30	0,24	0,19
	J	-	-	-	247,31	109,37	49,46	21,68	8,45	4,90	2,62	1,49	0,90	0,52	0,31	0,18
9,00	V	-	-	-	4,34	3,04	2,12	1,42	1,10	0,87	0,67	0,53	0,43	0,34	0,27	0,22
	J	-	-	-	304,08	133,09	59,39	25,56	15,52	6,03	3,22	1,83	1,11	0,64	0,38	0,22
10,00	V	-	-	-	4,82	3,38	2,35	1,57	1,22	0,97	0,74	0,59	0,48	0,38	0,30	0,24
	J	-	-	-	366,70	159,15	70,23	29,77	17,87	11,56	3,87	2,21	1,34	0,76	0,46	0,27

1 SYSTEM CHARACTERISTICS

2 STANDARDS AND QUALITY

3 OPERATING CONDITIONS

4 DESIGN

5 INSTALLATION

6 SYSTEM COMPONENTS

7 SERVICE AND GUARANTEE

Table 4.14 - Distributed pressure losses values in SDR 7.4 Alfaidro FASER pipes at 20°C

SDR 7,4 20 °C	Nominal diameter [mm]								
	20	25	32	40	50	63	75	90	110
	Wall thickness [mm]								
	2,8	3,5	4,4	5,5	6,9	8,6	10,3	12,3	15,1
Inside diameter [mm]									
14,4	18,0	23,2	29	36,2	45,8	54,4	65,4	79,8	

$\epsilon = 0,007 \text{ mm}$

$\rho = 998 \text{ kg/m}^3$

$\mu = 1,018 \times 10^{-3} \text{ kg/m s}$

q	q = Flow rate [l/sec]		V = Speed [m/s]			J = Pressure loss [mm/m]		
0,02	V	0,12	-	-	-	-	-	-
	J	1,94	-	-	-	-	-	-
0,03	V	0,18	0,12	-	-	-	-	-
	J	5,30	1,83	-	-	-	-	-
0,04	V	0,25	0,16	-	-	-	-	-
	J	8,76	3,04	-	-	-	-	-
0,05	V	0,31	0,20	0,12	-	-	-	-
	J	12,95	4,49	1,34	-	-	-	-
0,06	V	0,37	0,24	0,14	-	-	-	-
	J	17,81	6,17	1,85	-	-	-	-
0,07	V	0,43	0,28	0,17	0,11	-	-	-
	J	23,33	8,08	2,42	0,84	-	-	-
0,08	V	0,49	0,31	0,19	0,12	-	-	-
	J	29,47	10,21	3,06	1,06	-	-	-
0,09	V	0,55	0,35	0,24	0,14	-	-	-
	J	36,21	12,55	4,52	1,30	-	-	-
0,10	V	0,61	0,39	0,28	0,15	0,10	-	-
	J	43,55	15,09	6,22	1,57	0,55	-	-
0,12	V	0,74	0,47	0,33	0,18	0,12	-	-
	J	59,91	20,76	8,14	2,15	0,75	-	-
0,14	V	0,86	0,55	0,38	0,21	0,14	-	-
	J	78,47	27,19	10,29	2,82	0,98	-	-
0,16	V	0,98	0,63	0,43	0,24	0,16	0,10	-
	J	99,12	34,33	12,64	3,56	1,24	0,41	-
0,18	V	1,11	0,71	0,47	0,27	0,17	0,11	-
	J	121,81	42,21	15,20	4,37	1,53	0,50	-
0,20	V	1,23	0,79	0,51	0,30	0,19	0,12	-
	J	146,48	50,75	30,91	5,27	1,84	0,60	-
0,30	V	1,84	1,18	0,95	0,45	0,29	0,18	0,13
	J	197,8	103,18	51,14	10,71	3,73	1,22	0,54
0,40	V	2,46	1,57	1,18	0,61	0,39	0,24	0,17
	J	492,68	170,70	75,56	17,72	6,18	2,02	0,89
0,50	V	3,07	1,97	1,42	0,76	0,49	0,30	0,22
	J	728,05	252,25	106,96	26,18	9,13	2,99	1,32
0,60	V	3,69	2,36	1,66	0,91	0,58	0,36	0,26
	J	1001,67	347,06	136,16	36,02	12,56	4,11	1,81
0,70	V	4,30	2,75	1,89	1,06	0,68	0,43	0,30
	J	1311,85	454,53	172,00	47,18	16,45	5,38	2,38
0,80	V	4,91	3,15	2,13	1,21	0,78	0,49	0,34
	J	1657,18	574,18	211,37	59,59	20,78	6,80	3,00
0,90	V	-	3,54	2,37	1,36	0,87	0,55	0,39
	J	-	705,61	254,16	73,23	25,54	8,36	3,69
1,00	V	-	3,93	2,84	1,51	0,97	0,61	0,43
	J	-	848,48	349,69	88,06	30,71	10,05	4,44
1,20	V	-	4,72	3,31	1,82	1,17	0,73	0,52
	J	-	1167,36	547,97	121,16	42,26	13,82	6,10
1,40	V	-	-	3,79	2,12	1,36	0,85	0,60
	J	-	-	578,53	158,68	55,34	18,10	7,99
1,60	V	-	-	4,26	2,42	1,56	0,97	0,69
	J	-	-	710,96	200,45	69,91	22,87	10,10
1,80	V	-	-	4,73	2,73	1,75	1,09	0,77
	J	-	-	924,50	246,33	85,91	28,11	12,41
2,00	V	-	-	-	3,03	1,94	1,21	0,86
	J	-	-	-	296,21	103,30	33,80	14,92
2,20	V	-	-	-	3,33	2,14	1,34	0,95
	J	-	-	-	349,97	122,06	39,93	17,53
2,40	V	-	-	-	3,64	2,33	1,46	1,03
	J	-	-	-	443,85	142,13	46,50	20,53
2,60	V	-	-	-	3,94	2,53	1,58	1,12
	J	-	-	-	510,06	163,50	53,49	23,62
2,80	V	-	-	-	4,24	2,72	1,70	1,21
	J	-	-	-	580,87	186,14	60,90	26,89
3,00	V	-	-	-	4,54	2,92	1,82	1,29
	J	-	-	-	656,29	233,57	68,71	30,34
3,20	V	-	-	-	4,85	3,11	1,94	1,38
	J	-	-	-	736,30	260,33	76,93	33,97
3,40	V	-	-	-	-	3,31	2,06	1,46
	J	-	-	-	-	282,53	85,54	37,77
3,60	V	-	-	-	-	3,50	2,19	1,55
	J	-	-	-	-	318,19	94,54	41,75

Table 4.14 - Distributed pressure losses values in SDR 7.4 Alfaidro FASER pipes at 20°C

SDR 7,4 20 °C	Nominal diameter (mm)									
	20	25	32	40	50	63	75	90	110	
	Wall thickness (mm)									
	2,8	3,5	4,4	5,5	6,9	8,6	10,3	12,3	15,1	
Inside diameter (mm)										
	14,4	18,0	23,2	29	36,2	45,8	54,4	65,4	79,8	
$\varepsilon = 0,007 \text{ mm}$			$\rho = 998 \text{ kg/m}^3$				$\mu = 1,018 \times 10^{-3} \text{ kg/m s}$			
q	q = Flow rate (l/sec)				V = Speed (m/s)			J = Pressure loss (mm/m)		
3,80	V	-	-	-	-	3,69	2,31	1,64	1,13	0,76
	J	-	-	-	-	349,30	120,03	45,89	19,13	7,44
4,00	V	-	-	-	-	3,89	2,43	1,72	1,19	0,80
	J	-	-	-	-	381,86	130,36	50,20	20,93	8,13
4,20	V	-	-	-	-	4,08	2,55	1,81	1,25	0,84
	J	-	-	-	-	415,87	141,13	54,67	22,80	8,86
4,40	V	-	-	-	-	4,28	2,67	1,89	1,31	0,88
	J	-	-	-	-	451,33	152,32	71,65	24,73	9,61
4,60	V	-	-	-	-	4,47	2,79	1,98	1,37	0,92
	J	-	-	-	-	488,24	163,93	76,73	26,73	10,39
4,80	V	-	-	-	-	4,67	2,92	2,07	1,43	0,96
	J	-	-	-	-	526,60	175,98	82,00	28,80	11,19
5,00	V	-	-	-	-	4,86	3,04	2,15	1,49	1,00
	J	-	-	-	-	566,41	188,45	87,44	30,93	12,02
5,20	V	-	-	-	-	-	3,16	2,24	1,55	1,04
	J	-	-	-	-	-	201,35	93,05	42,54	12,87
5,40	V	-	-	-	-	-	3,28	2,32	1,61	1,08
	J	-	-	-	-	-	214,67	98,83	44,96	13,75
5,60	V	-	-	-	-	-	3,40	2,41	1,67	1,12
	J	-	-	-	-	-	228,42	104,80	47,45	14,66
5,80	V	-	-	-	-	-	3,52	2,50	1,73	1,16
	J	-	-	-	-	-	242,60	110,93	50,01	15,58
6,00	V	-	-	-	-	-	3,64	2,58	1,79	1,20
	J	-	-	-	-	-	257,21	117,24	52,63	16,54
6,20	V	-	-	-	-	-	3,77	2,67	1,85	1,24
	J	-	-	-	-	-	272,24	123,73	55,32	17,51
6,40	V	-	-	-	-	-	3,89	2,75	1,91	1,28
	J	-	-	-	-	-	287,70	130,39	58,08	25,61
6,60	V	-	-	-	-	-	4,01	2,84	1,97	1,32
	J	-	-	-	-	-	303,58	137,22	60,91	26,73
6,80	V	-	-	-	-	-	4,13	2,93	2,03	1,36
	J	-	-	-	-	-	319,89	144,23	63,80	27,87
7,00	V	-	-	-	-	-	4,25	3,01	2,08	1,40
	J	-	-	-	-	-	336,63	151,41	66,76	29,04
7,50	V	-	-	-	-	-	4,55	3,23	2,23	1,50
	J	-	-	-	-	-	380,35	170,14	74,45	32,06
8,00	V	-	-	-	-	-	4,86	3,44	2,38	1,60
	J	-	-	-	-	-	426,73	189,95	82,56	35,23
9,00	V	-	-	-	-	-	-	3,87	2,68	1,80
	J	-	-	-	-	-	-	232,85	100,04	42,01
10,00	V	-	-	-	-	-	-	4,30	2,98	2,00
	J	-	-	-	-	-	-	280,11	119,20	49,39

Table 4.15 - Distributed pressure losses values in SDR 6 Alfaidro and Alfaidro ALUMINIUM pipes at 20°C

SDR 6 20 °C	Nominal diameter (mm)									
	20	25	32	40	50	63	75	90	110	
	Wall thickness (mm)									
	3,4	4,2	5,4	6,7	8,3	10,5	12,5	15,0	18,4	
Inside diameter (mm)										
	13,2	16,6	21,2	26,6	33,2	42,0	50,0	60,6	73,2	
ε = 0,007 mm			ρ = 998 kg/m ³			μ = 1,018 x 10 ⁻³ kg/ m s				
q	q = Flow rate (l/sec)		V = Speed (m/s)			J = Pressure loss (mm/m)				
0,02	V	0,15	-	-	-	-	-	-	-	-
	J	2,74	-	-	-	-	-	-	-	-
0,03	V	0,22	0,14	-	-	-	-	-	-	-
	J	8,01	2,70	-	-	-	-	-	-	-
0,04	V	0,29	0,18	0,11	-	-	-	-	-	-
	J	13,25	4,46	1,40	-	-	-	-	-	-
0,05	V	0,37	0,23	0,14	-	-	-	-	-	-
	J	19,57	6,59	2,06	-	-	-	-	-	-
0,06	V	0,44	0,28	0,17	0,11	-	-	-	-	-
	J	26,93	9,07	2,84	0,97	-	-	-	-	-
0,07	V	0,51	0,32	0,20	0,13	-	-	-	-	-
	J	35,27	11,87	3,72	1,26	-	-	-	-	-
0,08	V	0,58	0,37	0,23	0,14	-	-	-	-	-
	J	44,55	15,00	4,69	1,60	-	-	-	-	-
0,09	V	0,66	0,42	0,26	0,16	0,10	-	-	-	-
	J	54,75	18,43	5,77	1,96	0,69	-	-	-	-
0,10	V	0,73	0,46	0,28	0,18	0,12	-	-	-	-
	J	65,84	22,17	6,94	2,36	0,82	-	-	-	-
0,12	V	0,88	0,55	0,34	0,22	0,14	-	-	-	-
	J	90,58	30,50	9,54	3,25	1,13	-	-	-	-
0,14	V	1,02	0,65	0,40	0,25	0,16	0,10	-	-	-
	J	118,63	39,94	12,50	4,25	1,48	0,49	-	-	-
0,16	V	1,17	0,74	0,45	0,29	0,18	0,12	-	-	-
	J	149,85	50,45	15,79	5,37	1,87	0,61	-	-	-
0,18	V	1,32	0,83	0,51	0,32	0,21	0,13	-	-	-
	J	184,16	62,00	19,40	6,60	2,30	0,75	-	-	-
0,20	V	1,46	0,92	0,57	0,36	0,23	0,14	0,10	-	-
	J	221,44	74,55	23,33	7,94	2,77	0,91	0,40	-	-
0,30	V	2,19	1,39	0,85	0,54	0,35	0,22	0,15	0,11	-
	J	450,21	151,58	47,43	16,14	5,63	1,84	0,81	0,34	-
0,40	V	2,92	1,85	1,13	0,72	0,46	0,29	0,20	0,14	0,10
	J	744,44	250,77	78,47	26,71	9,32	3,05	1,33	0,56	0,22
0,50	V	3,66	2,31	1,42	0,90	0,58	0,36	0,25	0,18	0,12
	J	1100,66	370,57	115,95	39,46	13,77	4,51	1,97	0,83	0,32
0,60	V	4,39	2,77	1,70	1,08	0,69	0,43	0,31	0,21	0,14
	J	1514,34	509,84	159,53	54,30	18,95	6,20	2,71	1,14	0,44
0,70	V	-	3,24	1,98	1,26	0,81	0,51	0,36	0,25	0,17
	J	-	667,72	208,93	71,11	24,81	8,12	3,55	1,49	0,58
0,80	V	-	3,70	2,27	1,44	0,92	0,58	0,41	0,28	0,19
	J	-	843,49	263,93	89,83	31,35	10,26	4,48	1,89	0,73
0,90	V	-	4,16	2,55	1,62	1,04	0,65	0,46	0,32	0,21
	J	-	1036,56	324,35	110,39	38,52	12,61	5,51	2,32	0,90
1,00	V	-	4,62	2,83	1,80	1,16	0,71	0,49	0,34	0,24
	J	-	1246,44	390,02	132,74	46,32	15,17	6,61	2,66	1,08
1,20	V	-	-	3,40	2,16	1,39	0,87	0,61	0,42	0,29
	J	-	-	536,61	182,63	63,73	20,86	9,11	3,83	1,49
1,40	V	-	-	3,97	2,52	1,62	1,01	0,71	0,50	0,33
	J	-	-	702,77	239,18	83,46	27,32	11,93	5,02	1,95
1,60	V	-	-	4,54	2,88	1,85	1,16	0,82	0,57	0,38
	J	-	-	887,77	302,14	105,44	34,51	15,08	6,34	2,47
1,80	V	-	-	-	3,24	2,08	1,30	0,92	0,64	0,43
	J	-	-	-	371,30	129,57	42,41	18,53	7,79	3,03
2,00	V	-	-	-	3,60	2,31	1,44	1,01	0,71	0,48
	J	-	-	-	446,48	155,80	51,00	22,28	9,37	3,64
2,20	V	-	-	-	3,96	2,54	1,59	1,12	0,78	0,52
	J	-	-	-	571,87	184,08	60,25	26,32	11,07	4,31
2,40	V	-	-	-	4,32	2,77	1,73	1,22	0,85	0,57
	J	-	-	-	666,42	214,36	70,16	30,65	12,89	5,01
2,60	V	-	-	-	4,68	3,00	1,88	1,32	0,92	0,62
	J	-	-	-	767,98	246,59	80,71	35,26	14,83	5,77
2,80	V	-	-	-	5,04	3,24	2,02	1,43	0,99	0,67
	J	-	-	-	876,87	308,88	91,89	40,14	16,88	6,91
3,00	V	-	-	-	-	3,47	2,17	1,53	1,06	0,71
	J	-	-	-	-	347,51	103,68	45,29	19,05	7,41
3,20	V	-	-	-	-	3,70	2,31	1,63	1,13	0,76
	J	-	-	-	-	388,42	116,08	50,71	21,33	8,29
3,40	V	-	-	-	-	3,93	2,46	1,73	1,20	0,81
	J	-	-	-	-	431,60	147,16	56,39	23,72	9,22
3,60	V	-	-	-	-	4,16	2,60	1,83	1,27	0,86
	J	-	-	-	-	477,06	161,54	62,32	26,21	10,19

Table 4.15 - Distributed pressure losses values in SDR 6 Alfaidro and Alfaidro ALUMINIUM pipes at 20°C

SDR 6 20 °C	Nominal diameter (mm)									
	20	25	32	40	50	63	75	90	110	
	Wall thickness (mm)									
	3,4	4,2	5,4	6,7	8,3	10,5	12,5	15,0	18,4	
Inside diameter (mm)										
	13,2	16,6	21,2	26,6	33,2	42,0	50,0	60,6	73,2	
$\epsilon = 0,007 \text{ mm}$			$\rho = 998 \text{ kg/m}^3$				$\mu = 1,018 \times 10^{-3} \text{ kg/m s}$			
q	q = Flow rate (l/sec)			V = Speed (m/s)			J = Pressure loss (mm/m)			
3,80	V	-	-	-	-	4,39	2,74	1,94	1,34	0,90
	J	-	-	-	-	524,79	176,58	68,50	28,81	11,20
4,00	V	-	-	-	-	4,62	2,89	2,04	1,42	0,95
	J	-	-	-	-	574,79	192,29	88,78	31,52	12,26
4,20	V	-	-	-	-	4,85	3,03	2,14	1,49	1,00
	J	-	-	-	-	627,08	208,68	95,85	34,33	13,35
4,40	V	-	-	-	-	5,09	3,18	2,24	1,56	1,05
	J	-	-	-	-	681,63	225,73	103,19	37,24	14,48
4,60	V	-	-	-	-	-	3,32	2,34	1,63	1,09
	J	-	-	-	-	-	243,45	110,79	40,25	15,65
4,80	V	-	-	-	-	-	3,47	2,45	1,70	1,14
	J	-	-	-	-	-	261,84	118,67	54,03	16,86
5,00	V	-	-	-	-	-	3,61	2,55	1,77	1,19
	J	-	-	-	-	-	280,90	126,82	57,45	18,11
5,20	V	-	-	-	-	-	3,76	2,65	1,84	1,24
	J	-	-	-	-	-	300,64	135,24	60,98	19,40
5,40	V	-	-	-	-	-	3,90	2,75	1,91	1,28
	J	-	-	-	-	-	321,04	143,93	64,61	20,72
5,60	V	-	-	-	-	-	4,04	2,85	1,98	1,33
	J	-	-	-	-	-	342,11	152,89	68,34	22,08
5,80	V	-	-	-	-	-	4,19	2,96	2,05	1,38
	J	-	-	-	-	-	363,85	162,12	72,18	31,48
6,00	V	-	-	-	-	-	4,33	3,06	2,12	1,43
	J	-	-	-	-	-	386,26	171,62	76,13	33,03
6,20	V	-	-	-	-	-	4,48	3,16	2,19	1,47
	J	-	-	-	-	-	409,34	181,40	80,18	34,63
6,40	V	-	-	-	-	-	4,62	3,26	2,26	1,52
	J	-	-	-	-	-	433,09	191,99	84,33	36,25
6,60	V	-	-	-	-	-	4,77	3,36	2,34	1,57
	J	-	-	-	-	-	457,51	201,75	88,59	37,92
6,80	V	-	-	-	-	-	4,91	3,46	2,41	1,62
	J	-	-	-	-	-	482,59	212,34	92,96	39,62
7,00	V	-	-	-	-	-	5,06	3,57	2,48	1,66
	J	-	-	-	-	-	508,35	223,19	97,43	41,36
7,50	V	-	-	-	-	-	-	3,82	2,65	1,78
	J	-	-	-	-	-	-	251,51	109,06	45,87
8,00	V	-	-	-	-	-	-	4,08	2,83	1,90
	J	-	-	-	-	-	-	281,52	121,35	50,62
9,00	V	-	-	-	-	-	-	4,59	3,18	2,14
	J	-	-	-	-	-	-	346,61	147,89	60,81
10,00	V	-	-	-	-	-	-	-	3,54	2,38
	J	-	-	-	-	-	-	-	177,06	71,94

Table 4.16 - Distributed pressure losses values in SDR 6 Alfaidro and Alfaidro ALUMINIUM pipes at 60°C

SDR 6 60 °C	Nominal diameter (mm)									
	20	25	32	40	50	63	75	90	110	
	Wall thickness (mm)									
	3,4	4,2	5,4	6,7	8,3	10,5	10,5	12,5	18,4	
Inside diameter (mm)										
	13,2	16,6	21,2	26,6	33,2	42,0	42,0	50,0	73,2	
ε = 0,007 mm			ρ = 998 kg/m ³			μ = 1,018 x 10 ⁻³ kg/m s				
q	q = Flow rate (l/sec)		V = Speed (m/s)			J = Pressure loss (mm/m)				
0,02	V	0,15	-	-	-	-	-	-	-	-
	J	3,26	-	-	-	-	-	-	-	-
0,03	V	0,22	0,14	-	-	-	-	-	-	-
	J	6,63	2,23	-	-	-	-	-	-	-
0,04	V	0,29	0,18	0,11	-	-	-	-	-	-
	J	10,96	3,69	1,15	-	-	-	-	-	-
0,05	V	0,37	0,23	0,14	-	-	-	-	-	-
	J	16,20	5,45	1,71	-	-	-	-	-	-
0,06	V	0,44	0,28	0,17	0,11	-	-	-	-	-
	J	22,28	7,50	2,35	0,80	-	-	-	-	-
0,07	V	0,51	0,32	0,20	0,13	-	-	-	-	-
	J	29,19	9,83	3,07	1,05	-	-	-	-	-
0,08	V	0,58	0,37	0,23	0,14	-	-	-	-	-
	J	36,87	12,41	3,88	1,32	-	-	-	-	-
0,09	V	0,66	0,42	0,26	0,16	0,10	-	-	-	-
	J	45,31	15,25	4,77	1,62	0,57	-	-	-	-
0,10	V	0,73	0,46	0,28	0,18	0,12	-	-	-	-
	J	55,48	18,34	5,74	1,95	0,68	-	-	-	-
0,12	V	0,88	0,55	0,34	0,22	0,14	-	-	-	-
	J	74,96	25,24	7,90	2,69	0,94	-	-	-	-
0,14	V	1,02	0,65	0,40	0,25	0,16	0,10	-	-	-
	J	98,17	33,05	10,34	3,52	1,23	0,40	-	-	-
0,16	V	1,17	0,74	0,45	0,29	0,18	0,12	-	-	-
	J	124,01	41,75	13,06	4,45	1,55	0,51	-	-	-
0,18	V	1,32	0,83	0,51	0,32	0,21	0,13	-	-	-
	J	152,39	51,31	16,05	5,46	1,91	0,62	-	-	-
0,20	V	1,46	0,92	0,57	0,36	0,23	0,14	0,10	-	-
	J	183,25	61,70	19,31	6,57	2,29	0,75	0,33	-	-
0,30	V	2,19	1,39	0,85	0,54	0,35	0,22	0,15	0,11	-
	J	372,37	125,43	39,25	13,36	4,66	1,53	0,67	0,28	-
0,40	V	2,92	1,85	1,13	0,72	0,46	0,29	0,20	0,14	0,10
	J	616,38	207,52	64,93	22,10	7,71	2,52	1,10	0,46	0,18
0,50	V	3,66	2,31	1,42	0,90	0,58	0,36	0,25	0,18	0,12
	J	1005,49	306,66	95,96	32,66	11,40	3,73	1,63	0,69	0,27
0,60	V	4,39	2,77	1,70	1,08	0,69	0,43	0,31	0,21	0,14
	J	1415,07	421,91	132,02	44,93	15,68	5,13	2,24	0,94	0,37
0,70	V	-	3,24	1,98	1,26	0,81	0,51	0,36	0,25	0,17
	J	-	605,95	172,90	58,84	20,53	6,72	2,94	1,24	0,48
0,80	V	-	3,70	2,27	1,44	0,92	0,58	0,41	0,28	0,19
	J	-	776,36	235,60	74,33	25,94	8,49	3,71	1,56	0,61
0,90	V	-	4,16	2,55	1,62	1,04	0,65	0,46	0,32	0,21
	J	-	967,85	291,20	91,35	31,88	10,43	4,56	1,92	0,75
1,00	V	-	4,62	2,83	1,80	1,16	0,72	0,51	0,35	0,24
	J	-	1180,44	352,69	119,10	38,33	12,55	5,48	2,31	0,90
1,20	V	-	-	3,40	2,16	1,39	0,87	0,61	0,42	0,29
	J	-	-	493,33	164,17	52,74	17,26	7,54	3,17	1,23
1,40	V	-	-	3,97	2,52	1,62	1,01	0,71	0,50	0,33
	J	-	-	657,52	216,45	75,79	22,61	9,88	4,15	1,62
1,60	V	-	-	4,54	2,88	1,85	1,16	0,82	0,57	0,38
	J	-	-	845,25	275,95	95,49	32,55	12,48	5,15	2,04
1,80	V	-	-	-	3,24	2,08	1,30	0,92	0,64	0,43
	J	-	-	-	342,66	117,48	39,48	15,33	6,45	2,51
2,00	V	-	-	-	3,60	2,31	1,44	1,02	0,71	0,48
	J	-	-	-	416,58	141,74	47,09	21,60	7,75	3,02
2,20	V	-	-	-	3,96	2,54	1,59	1,12	0,78	0,52
	J	-	-	-	497,73	168,27	55,37	25,15	9,16	3,56
2,40	V	-	-	-	4,32	2,77	1,73	1,22	0,85	0,57
	J	-	-	-	586,09	197,08	64,31	28,97	13,09	4,15
2,60	V	-	-	-	4,68	3,00	1,88	1,32	0,92	0,62
	J	-	-	-	681,66	228,17	73,93	33,07	14,80	4,77
2,80	V	-	-	-	5,04	3,24	2,02	1,43	0,99	0,67
	J	-	-	-	784,45	261,53	84,21	37,43	16,61	5,43
3,00	V	-	-	-	-	3,47	2,17	1,53	1,06	0,71
	J	-	-	-	-	297,17	95,17	42,07	18,53	6,13
3,20	V	-	-	-	-	3,70	2,31	1,63	1,13	0,76
	J	-	-	-	-	335,08	106,79	46,98	20,56	6,86
3,40	V	-	-	-	-	3,93	2,46	1,73	1,20	0,81
	J	-	-	-	-	375,27	119,09	52,15	22,69	7,63

- 1 SYSTEM CHARACTERISTICS
- 2 STANDARDS AND QUALITY
- 3 OPERATING CONDITIONS
- 4 DESIGN
- 5 INSTALLATION
- 6 SYSTEM COMPONENTS
- 7 SERVICE AND GUARANTEE

Table 4.16 - Distributed pressure losses values in SDR 6 Alfaidro and Alfaidro ALUMINIUM pipes at 60°C

SDR 6 60 °C	Nominal diameter (mm)								
	20	25	32	40	50	63	75	90	110
	Wall thickness (mm)								
	3,4	4,2	5,4	6,7	8,3	10,5	10,5	12,5	18,4
Inside diameter (mm)									
	13,2	16,6	21,2	26,6	33,2	42,0	42,0	50,0	73,2

$\epsilon = 0,007 \text{ mm}$

$\rho = 998 \text{ kg/m}^3$

$\mu = 1,018 \times 10^{-3} \text{ kg/m s}$

q		q = Flow rate (l/sec)			V = Speed (m/s)		J = Pressure loss (mm/m)			
3,60	V	-	-	-	-	4,16	2,60	1,83	1,27	0,86
	J	-	-	-	-	417,73	132,05	57,60	24,92	8,43
3,80	V	-	-	-	-	4,39	2,74	1,94	1,34	0,90
	J	-	-	-	-	462,47	145,69	63,32	27,26	9,27
4,00	V	-	-	-	-	4,62	2,89	2,04	1,42	0,95
	J	-	-	-	-	509,48	159,99	69,31	29,71	10,14
4,20	V	-	-	-	-	4,85	3,03	2,14	1,49	1,00
	J	-	-	-	-	558,77	174,96	75,57	32,26	11,05
4,40	V	-	-	-	-	5,09	3,18	2,24	1,56	1,05
	J	-	-	-	-	610,34	190,61	82,10	34,91	11,98
4,60	V	-	-	-	-	-	3,32	2,34	1,63	1,09
	J	-	-	-	-	-	206,92	88,90	37,67	12,95
4,80	V	-	-	-	-	-	3,47	2,45	1,70	1,14
	J	-	-	-	-	-	223,90	95,97	40,53	13,95
5,00	V	-	-	-	-	-	3,61	2,55	1,77	1,19
	J	-	-	-	-	-	241,55	103,31	43,50	14,99
5,20	V	-	-	-	-	-	3,76	2,65	1,84	1,24
	J	-	-	-	-	-	259,88	110,92	46,58	16,05
5,40	V	-	-	-	-	-	3,90	2,75	1,91	1,28
	J	-	-	-	-	-	278,87	118,80	49,76	17,15
5,60	V	-	-	-	-	-	4,04	2,85	1,98	1,33
	J	-	-	-	-	-	298,53	126,96	53,04	18,28
5,80	V	-	-	-	-	-	4,19	2,96	2,05	1,38
	J	-	-	-	-	-	318,86	135,38	56,43	19,43
6,00	V	-	-	-	-	-	4,33	3,06	2,12	1,43
	J	-	-	-	-	-	339,86	144,08	59,92	20,62
6,20	V	-	-	-	-	-	4,48	3,16	2,19	1,47
	J	-	-	-	-	-	361,53	153,04	63,52	21,84
6,40	V	-	-	-	-	-	4,62	3,26	2,26	1,52
	J	-	-	-	-	-	383,87	162,28	67,23	23,09
6,60	V	-	-	-	-	-	4,77	3,36	2,34	1,57
	J	-	-	-	-	-	406,88	171,78	71,03	24,36
6,80	V	-	-	-	-	-	4,91	3,46	2,41	1,62
	J	-	-	-	-	-	430,56	181,56	74,95	25,67
7,00	V	-	-	-	-	-	5,06	3,57	2,48	1,66
	J	-	-	-	-	-	454,90	191,61	78,97	27,01
7,50	V	-	-	-	-	-	-	3,82	2,65	1,78
	J	-	-	-	-	-	-	217,91	89,47	30,47
8,00	V	-	-	-	-	-	-	4,08	2,83	1,90
	J	-	-	-	-	-	-	245,90	100,63	34,12
9,00	V	-	-	-	-	-	-	4,59	3,18	2,14
	J	-	-	-	-	-	-	306,96	124,92	41,92
10,00	V	-	-	-	-	-	-	3,54	2,38	1,62
	J	-	-	-	-	-	-	151,84	50,41	17,15

1 SYSTEM CHARACTERISTICS

2 STANDARDS AND QUALITY

3 OPERATING CONDITIONS

4 DESIGN

5 INSTALLATION

6 SYSTEM COMPONENTS

7 SERVICE AND GUARANTEE

4.3.2 LOCALISED PRESSURE LOSSES

The localised pressure losses can be expressed by the following formula:

$$J_1 = \sum \left(\zeta \cdot \frac{\rho \cdot v^2}{2g} \right) \approx 5 \cdot 10^4 \cdot \sum (\zeta \cdot v^2)$$

wherein:

J_1 localised pressure loss, in millimetres;

ζ coefficient of localised resistance ;

ρ , v and g have been defined already (part 5.3.1.)

The coefficients of localised resistance ζ are connected to the type of fitting and they are obtained from practical experience





















The ζ values of Alfaidro fittings are shown in table 5.14.













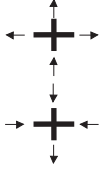





The sum of localised and distributed pressure losses provides the total values of pressure losses:

$$J = J_d \cdot l + J_1$$

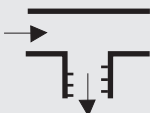
wherein: J total pressure loss, in millimetres ; l pipe length, in metres;

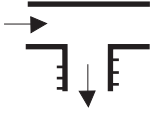
Table 5.16 Coefficient of localised resistance values

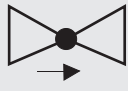
Fitting	Description	Notes	Symbol	Coefficient ζ
	Coupling	All dimensions		0,25
	Reducing coupling	one dimensions		0,30
		two dimensions		0,50
		three dimensions		0,55
		> of three dimensions		0,85
	90° elbow	All dimensions		0,90
	90° M-F elbow	All dimensions		0,90
	45° elbow	All dimensions		0,40
	Weld Saddle	Direct passage		0,25
		Branch		0,50
		Convergent flow		1,00
	Tee	Direct passage		0,50
		Branch		1,20
		Junction		0,80
		Convergent flow		3,00
		Divergent flow		1,80

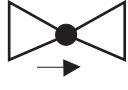
Fitting	Description	Notes	Symbol	Coefficient ζ
	Reducing tee	All dimensions		The value of ζ is the sum of the coefficients of resistance of the tee and the reduction
	Cross	Branch Junction		2,10 3,70
	Female threaded adaptor	All dimensions		0,40
	Male threaded adaptor	All dimensions		0,50
	90° female threaded elbow	All dimensions		1,40
	90° male threaded elbow	All dimensions		1,60
	Female threaded tee	All dimensions		1,50
	Male threaded tee	All dimensions		1,80
	Stop cock	$\varnothing 20$ $\varnothing 25$		13,00 11,00
	Ball valve	All dimensions		0,25



ALFAIDRO

INSTALLATION 5

5.1 THERMAL EXPANSION

Thermal expansion is the dimensional change of a body owing to an increase or fall of temperature. The expansion occurs in the molecules: the heat sets the molecules in motion increasing their kinetic energy and causing the body expansion. When the expansion occurs in one direction only, it is called linear thermal expansion, when it occurs in all directions it is called cubic thermal expansion.

The linear expansion fundamentally occurs in piping systems since length is the prevalent dimension. This phenomenon has to be taken into account during the installation of pipelines conveying hot water, passing outside or going through areas subjected to a temperature range such as to alter the material.

The variation in length of Alfaidro pipes due to variation in temperature is obtained by the following formula:

$$\Delta l = \alpha \cdot l \cdot \Delta t$$

wherein:

Δl variation in length of the pipe, in millimetres;

α coefficient of linear thermal expansion;

l length of the pipe section subjected to expansion, in metres;

Δt difference between the ambient and the water temperature, in °C.

and, in particular, the coefficient (α) of linear expansion of **Alfaidro Faser** and **Alfaidro Aluminium** pipes is comparable to the linear expansion of metal pipe:

α_1 coefficient of linear thermal expansion, for Alfaidro Faser pipes is 0.035 mm/m °C

α_2 coefficient of linear thermal expansion, for Alfaidro Plus pipes is 0.030 mm/m °C

while the coefficient (α) of linear expansion of Alfaidro monolayer pipes is approximately five times greater than **Faser** and **Aluminium**:

α_3 coefficient of linear thermal expansion, for **Alfaidro** pipes is 0.16 mm/m °C

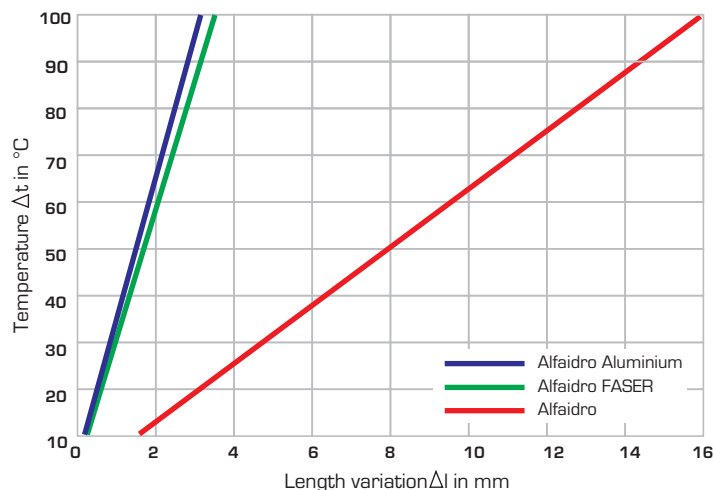

Figure 5.1 - Comparative linear thermal expansion

EXAMPLE

It lays an **Alfaidro Faser** pipe 100 m long into the open

- extreme achievable temperatures: -5 °C and +30 °C
- laying temperature: +15 °C
- $\Delta l_1 = 0.035 \cdot 100 \cdot [-5 - 15] = -70$ mm

The pipe undergoes contraction.

$$\Delta l_2 = 0.035 \cdot 100 \cdot [30 - 15] = 52.5 \text{ mm}$$

The pipe undergoes expansion.

ΔL can be quickly calculated using the tables and the diagrams show below installation in ducts.

Linear thermal expansion ΔL (mm)



Pipe length	Temperature difference ΔT (°C)									
	10	20	30	40	50	60	70	80	90	100
1	1,6	3,2	4,8	6,4	8,0	9,6	11,2	12,8	14,4	16,0
2	3,2	6,4	9,6	12,8	16,0	19,2	22,4	25,6	28,8	32,0
3	4,8	9,6	14,4	19,2	24,0	28,8	33,6	38,4	43,2	48,0
4	6,4	12,8	19,2	25,6	32,0	38,4	44,8	51,2	57,6	64,0
5	8,0	16,0	24,0	32,0	40,0	48,0	56,0	64,0	72	80,0
6	9,6	19,2	28,8	38,4	48,0	57,6	67,2	76,8	86,4	96,0
7	11,2	22,4	33,6	44,8	56,0	67,2	78,4	89,6	100,8	112,0
8	12,8	25,6	38,4	51,2	64,0	76,8	89,6	102,4	115,2	128,0
9	14,4	28,8	43,2	57,6	72,0	86,4	100,8	115,2	129,6	144,0
10	16	32	48,0	64,0	80,0	96,0	112	128	144	160,0

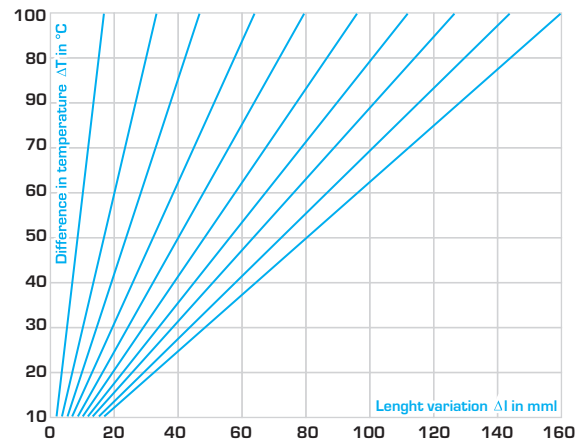

Linear thermal expansion ΔL (mm)



Pipe length	Temperature difference ΔT (°C)									
	10	20	30	40	50	60	70	80	90	100
1	0,35	0,7	1,1	1,4	1,75	2,1	2,4	2,8	3,2	3,5
2	0,7	1,4	2,1	2,8	3,5	4,2	4,9	5,6	6,3	7,0
3	1,1	2,1	3,2	4,2	5,25	6,3	7,4	8,4	9,5	10,5
4	1,4	2,8	4,2	5,6	7,0	8,4	9,8	11,2	12,6	14
5	1,8	3,5	5,2	7,0	8,75	10,5	12,3	14,1	15,8	17,5
6	2,1	4,2	6,3	8,4	10,5	12,6	14,7	16,8	18,9	21
7	2,5	4,9	7,4	9,8	12,25	14,7	17,2	19,6	22,0	24,5
8	2,8	5,6	8,4	11,2	14	16,8	19,6	22,4	25,2	28
9	3,2	6,3	9,5	12,6	15,75	18,9	22,1	25,2	28,4	31,5
10	3,5	7	10,5	14	17,5	21	24,5	28,6	32,5	35

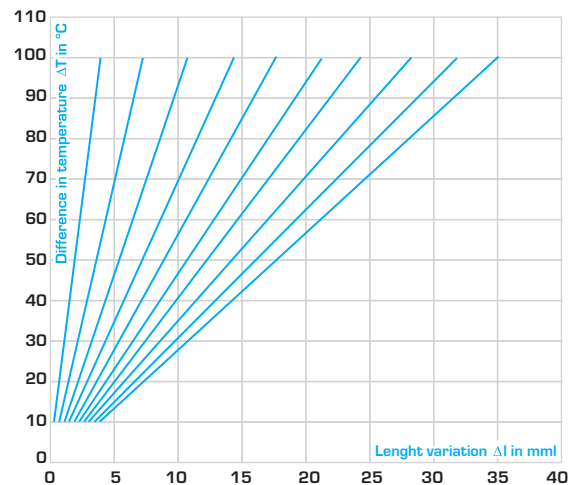

Linear thermal expansion ΔL (mm)



Pipe length	Temperature difference ΔT (°C)									
	10	20	30	40	50	60	70	80	90	100
1	0,3	0,6	0,9	1,2	1,5	1,8	2,1	2,4	2,7	3,0
2	0,6	1,2	1,8	2,4	3,0	3,6	4,2	4,8	5,4	6,0
3	0,9	1,8	2,7	3,6	4,5	5,4	6,3	7,2	8,1	9,0
4	1,2	2,4	3,6	4,8	6,0	7,2	8,4	9,6	10,8	12,0
5	1,5	3,0	4,5	6,0	7,5	9,0	10,5	12,0	13,5	15,0
6	1,8	3,6	5,4	7,2	9,0	10,8	12,6	14,4	16,2	18,0
7	2,1	4,2	6,3	8,4	10,5	12,6	14,7	16,8	18,9	21,0
8	2,4	4,8	7,2	9,6	12,0	14,4	16,8	19,2	21,6	24,0
9	2,7	5,4	8,1	10,8	13,5	16,2	18,9	21,6	24,3	27,0
10	3,0	6,0	9,0	12,0	15,0	18,0	21,0	24,0	27,0	30,0

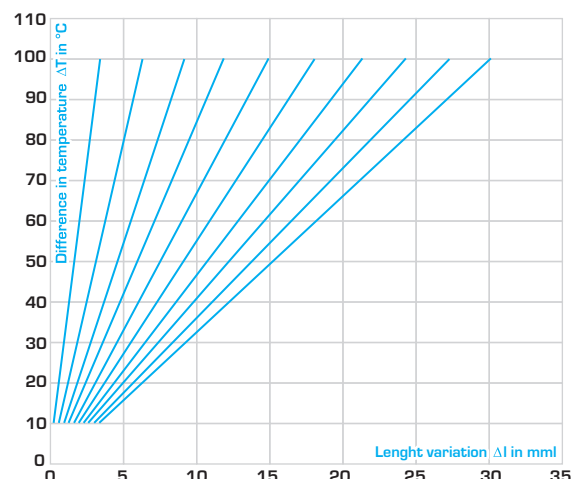

It is possible to avoid the thermal expansion using the following structures:

- fixed and sliding points;
- compensating structures: curve arms and expansion loops..

First, it is necessary to distinguish between the following kinds of installation:

- free installation;
- built-in installation;
- installation in ducts.

5.1.1. FREE INSTALLATION

Fixed and sliding points are obtained by metal collars, firmly anchored to the wall; they clamp the pipe blocking it or allowing it to slide. The collars are covered by rubber material or similar in order to protect the pipe surface from notching.

■ **Fixed points** prevent the pipe from moving and are used to section the system, decreasing the Δl value. For **Alfaidro** pipes the maximum distance between fixed points is 3-4 mt in linear installations, while in risers they are set by the changes of direction, such as elbows, in order to prevent expansion from exerting its force on these points. **Alfaidro Faser** and **Aluminium** pipes must have enough space to expand and an expansion control is required for long and straight pipes (over 40 mt).

The linear expansion of **Alfaidro Faser** and **Aluminium pipes** in vertical risers can be ignored and the pipes can be installed rigidly without compensation.

The positioning of a fixed point directly before each branch is sufficient to keep the branch line from shifting under expansion.

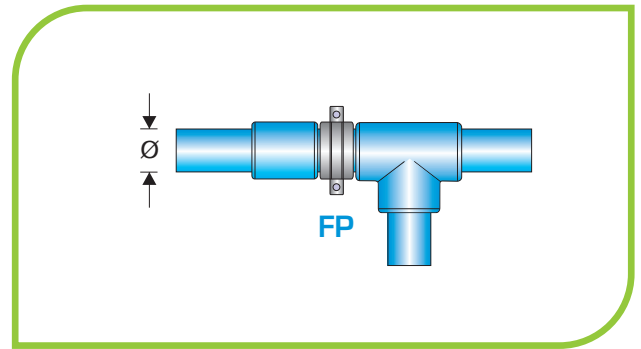

Figure 5.2 - Fixed point example

■ Sliding points

Are used to line up the installation, allowing the axial sliding of the pipes. They are to be positioned, both in vertical and in horizontal position, by a free length of pipe so as to allow it to slide. The sliding points, when put in sufficient quantity, also act as support assuring the conservation of the system rectilinear structure, even if undergoing thermal stress.

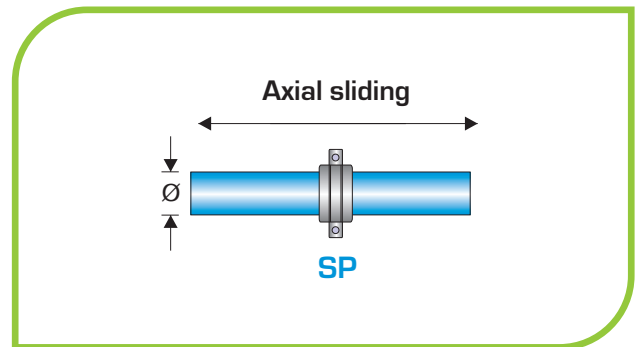

Figure 5.3 - Sliding point example

An excessive distance between the points can cause the deformation of the cross section.

The following table is a practical guide to localise the sliding points.

Table 5.1 - Support distance

Temperature Difference °C	Pipe outside diameter mm									
	32	40	50	63	75	90	110	125	160	
	Support distance in cm									
10	90	100	120	140	160	160	180	200	225	

Temperature Difference °C	Pipe outside diameter mm									
	32	40	50	63	75	90	110	125	160	
	Support distance in cm									
0	155	175	200	225	240	255	285	300	310	
20	115	130	150	170	180	190	210	225	225	
30	115	130	150	170	180	190	200	210	215	
40	105	120	140	160	170	180	190	200	205	
50	105	120	140	160	170	180	180	185	195	
60	100	115	130	150	160	170	170	175	185	
70	90	105	125	140	155	155	160	165	175	

Temperature Difference °C	Pipe outside diameter mm									
	20	25	32	40	50	63	75	90	110	
	Support distance in cm									
0	85	105	125	140	165	190	205	220	220	
20	60	75	90	100	120	140	150	160	160	
30	60	75	90	100	120	140	150	160	160	
40	60	70	80	90	110	130	140	150	150	
50	60	70	80	90	110	130	140	150	150	
60	55	65	75	85	100	115	125	140	140	
70	50	60	75	80	95	105	115	125	125	

Temperature Difference °C	Pipe outside diameter mm									
	20	25	32	40	50	63	75	90	110	
	Support distance in cm									
0	120	140	160	180	205	230	245	260	290	
20	90	105	120	135	155	175	185	195	215	
30	90	105	120	135	155	175	185	195	210	
40	85	95	110	125	145	165	175	185	200	
50	85	95	110	125	145	165	175	185	190	
60	80	90	105	120	135	155	165	175	180	
70	70	80	95	110	130	145	165	165	170	

N.B: In vertical risers the support distance can be increased by multiplying the values in tables per 1,2.

Curve arms

Using these structures (fig. 5.5), the expansion is totally absorbed by the course of the pipeline. Curve arms are to be positioned by the system direction changes (elbows, tees, etc.) putting a fixed or sliding point just after the curve at a distance l_s that can be worked out using the following formula:

$$l_s = C \cdot \sqrt{d \cdot \Delta l}$$

wherein:

arm length, in millimetres;

material factor of proportionality. Table 5.11 shows the C values

l_s experimentally obtained in case of a single rise of temperature;

C material factor of proportionality, for PPR=15;

d Pipe outside diameter, in millimetres;

Δl pipe length variation from the fixed point, in millimetres.

Figure 5.4 shows the diagram to calculate the arm length graphically.

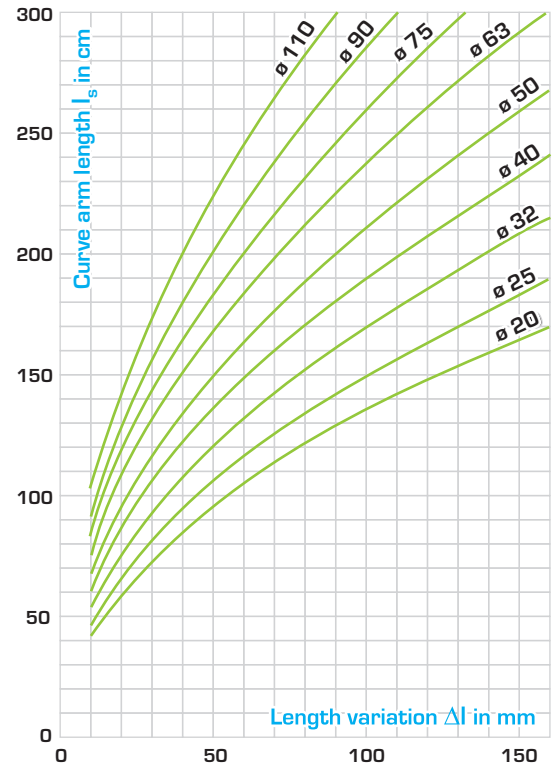

Fig.5.4 - Diagram for determination of the curve arm length

Expansion loops

When the variation in length cannot be compensated by a change in pipe direction, expansion loops must be used. They work as a double curve arm and are usually installed between two fixed points (Fig. 5.6).

An expansion loop is made of four 90° elbows together with the necessary pipe; the length l_s is calculated according to the formula mentioned for curve arms, while the width l_c can be worked out using the following formula:

$$l_c = 2 \cdot \Delta l \cdot D_s$$

wherein:

l_c compensating ring width, in millimetres;

Δl pipe length variation, in millimetres;

D_s safety distance, a constant independent from the thickness: PPR value is 150 mm.

Preloading

In limited spaces, it is possible to decrease the width l_c and the length l_s of the curve arm by pre-stressing the pipe.

For the calculation of the preloaded curve arms use the following formula:

$$l_{sp} = C \cdot \sqrt{d \cdot \Delta l / 2}$$

The pipeline will present aesthetically perfect because the expansion is almost invisible.

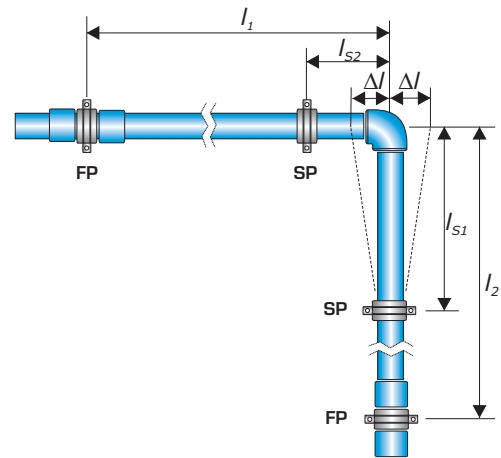

Fig.5.5 - Curve arm example

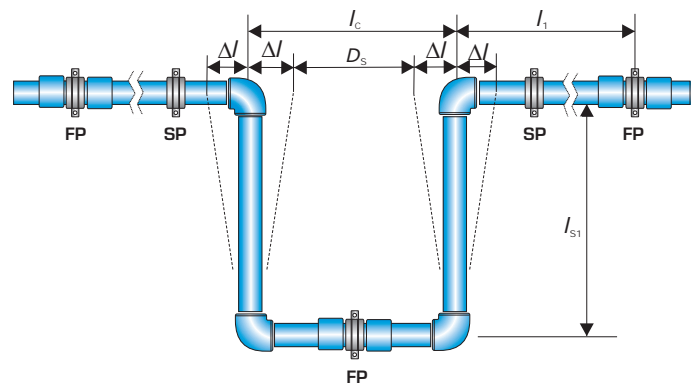

Fig.5.6 - Expansion loop example

■ Graphical examples of fixed and sliding points in free installations

1 SYSTEM CHARACTERISTICS

2 STANDARDS AND QUALITY

3 OPERATING CONDITIONS

4 DESIGN

5 INSTALLATION

6 SYSTEM COMPONENTS

7 SERVICE AND GUARANTEE

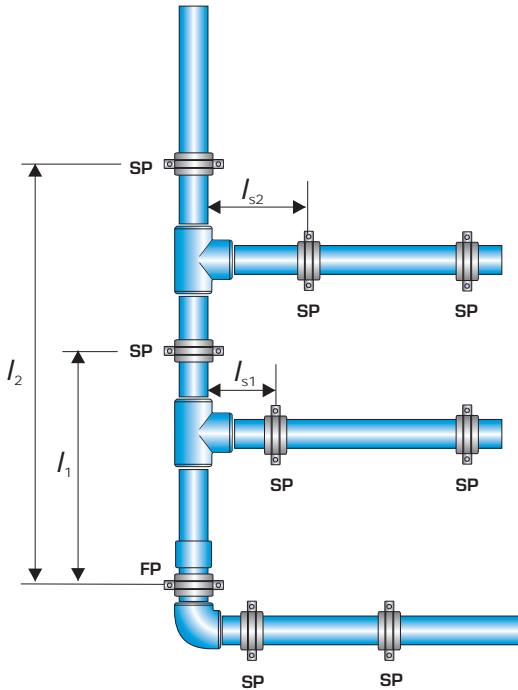

Fig. 5.7 - Fixed point at the riser basis (favourable position for two-floor maximum height)

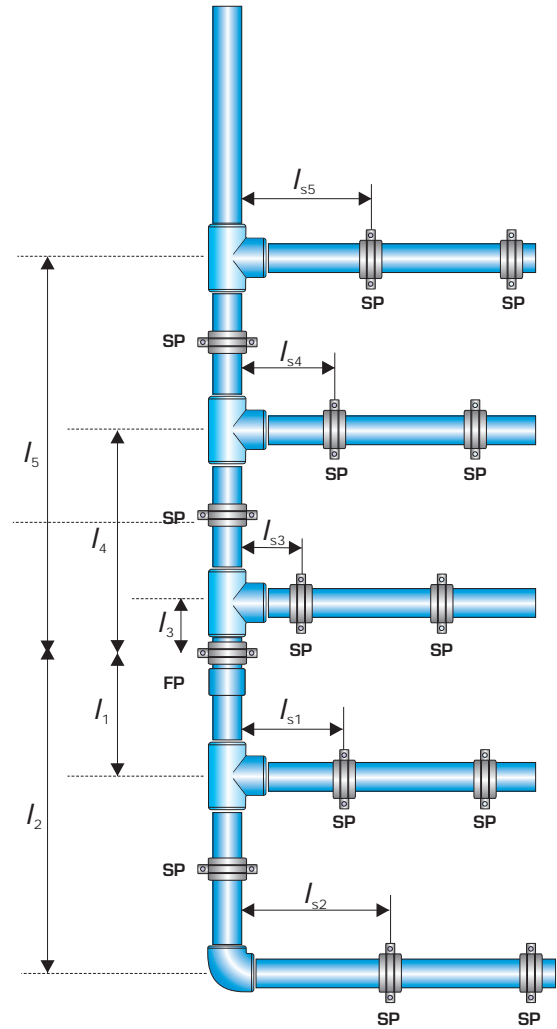

Fig. 5.8 - Fixed point at the riser centre (favourable position for multi-floor installations)

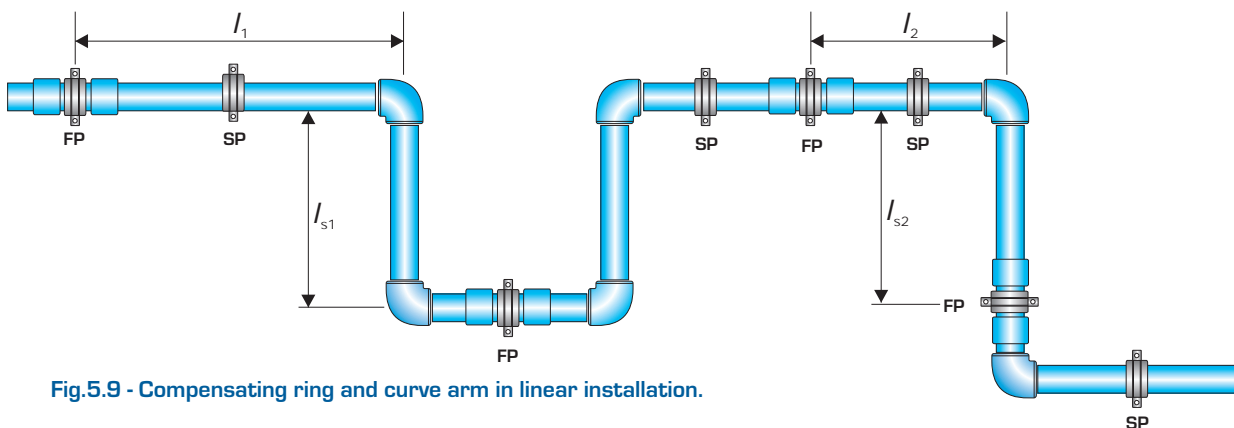

Fig.5.9 - Compensating ring and curve arm in linear installation.

5.1.2 BUILT-IN INSTALLATION

Unlike most piping materials, PP-R is able to absorb the stress caused by expansion within certain limits. In **Alfaidro Faser** and **Alfaidro Aluminium** pipe, the PPRGF and aluminium layer helps keep the pipe within these limits for most applications.

Alfaidro Faser and **Aluminium** installations generally do not require additional consideration for the expansion, moreover insulations give enough expansion space for the pipe. The same applies to pipes which do not have to be insulated according to current regulations. The expansion on pipes that don't need to be insulated is minimal because of the lower difference in temperature and the pipe itself can absorb the remaining stress.

5.1.3 INSTALLATION IN DUCTS

Due to the different linear expansion values of Alfaidro, Alfaidro Faser and Alfaidro Aluminium pipes, the installation of pipe branches in risers depends on the type of pipe used.

Explaining this, below are shown some graphical examples.

Fig. 5.10:

Using **Alfaidro pipes**, if the length of the rectilinear pipe is more than 8 metres and high temperature changes are expected in this section, expansion loops are necessary. Using **Alfaidro Faser** and **Alfaidro Aluminium pipes**, the risers may be installed rigidly without compensating rings, it is sufficient to place a fixing point next to each branch

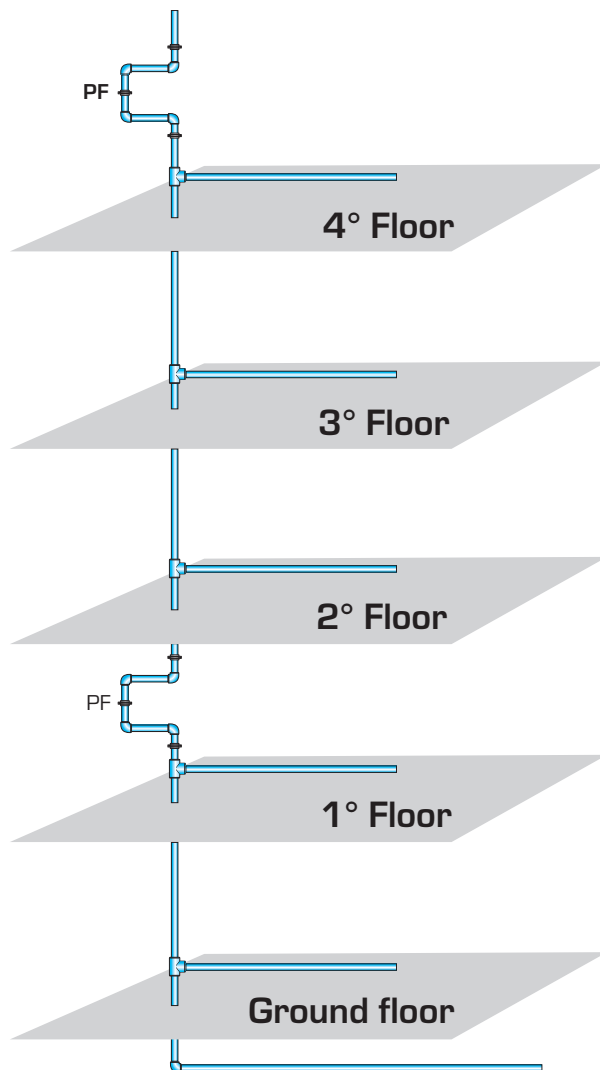

Fig. 5.11:

If the pipe buried in the concrete is such as to create a fixed point, the distance between the riser and the fixed point has to do as curve arm whose length is calculated by the formula shown at 5.1.1.

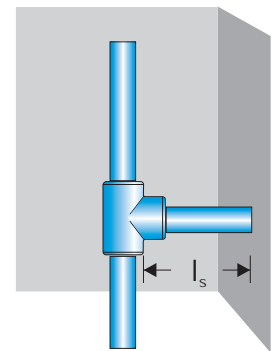

Fig. 5.12:

If the offtake of a riser goes through a wall, the hole on the wall has to be so as to allow the riser to expand without tensioning the offtake.

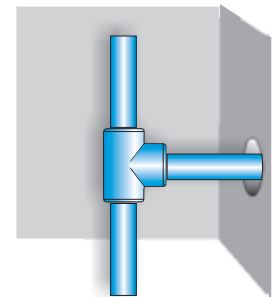
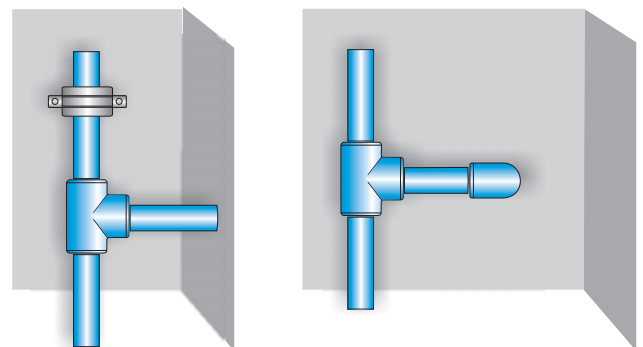

Fig. 5.13:

Should it not be possible to make a hole, a fixed point must be placed in the riser by the offtake or a curve arm by a 90° elbow gives the appropriate elasticity.



5.2 INSULATION AND CONDENSATE

Hot water supply

For hot water piping systems, the Italian law DL 10/91, integrated by DPR 26 agosto 1993 n. 412 and made operative by UNI 10376, law 10 of 9/01/1991 provides the insulating conditions in relation to the conductivity coefficient and the pipe diameter.

The thermal conductivity of PP-R Alfaidro is 0.15 W/(m K); compared to metal pipes the temperature lowering is reduced to a minimum and with the same thickness of insulation there is a greater energy savings.

Cold water supply

For cold water piping systems, **Alfaidro pipes and fittings** can be chased and no insulation is required. In particular, if the difference between the fluid temperature and the ambient temperature is above the values shown in table 5.2, condensate is produced and consequently the pipe has to be insulated. Below these values, insulation is not necessary

Table 5.2 - Condensation temperatures

Pipe diameter mm	Temperature difference °C
20	7,2
25	7,4
32	8,0
40	8,2
50	10,0
63	10,2
75	10,4
90	10,6
110	10,8

Values referred to PN20 pipe

The table below shows the indicative values of the minimum insulation thickness according to DIN 1988:

Installation Situation	Insulation layer thickness at $\lambda = 0,040$ W/mK
Pipelines in unheated rooms, uncovered installation (e.g. basement)	4 mm
Pipelines in heated rooms, uncovered installation	9 mm
Pipelines installed in sewers, no hot water lines next to them	4 mm
Pipelines installed in sewers, next to hot water lines	13 mm
Pipelines in wall slots, ascending	4 mm
Pipelines in wall recesses, next to hot water lines	13 mm
Pipelines on concrete floor	4 mm

Particular care should be taken in the case of pipes for conditioning and refrigeration, in which the possibility of condensation is greatly affected by humidity and outside temperature.

5.3 JOINTING METHODS

The jointing methods of **Alfaidro**, **Alfaidro Faser** and **Alfaidro Aluminium** are simple and quick; there are three types of welding: socket welding, butt welding and electro-fusion. Instructions to carry out a correct welding will follow. Reference is made to the draft standard issued by UNI about the welding methods.

Please carefully read the instructions of the welding machine.

5.3.1 SOCKET WELDING

This technique is carried out by heating the outside pipe surface and the inside fitting surface simultaneously on the matrix of an heating element: the welding machine.

When the welding temperature is reached, the two pieces are moved away from the heating source and inserted one into the other up to the predetermined depth. A watertight assembling is done.

There are two kinds of welding machines:

- 1 manual welding machine, bench-type welding machine, it is recommended to obtain welding up to dn 125 mm with the minimum physical strain and the maximum security.
- 2 bench-type welding machine, it is recommended to obtain welding up to dn 125 mm with the minimum physical strain and the maximum security.

Preliminary operations

- 1 Using the shear (cod. OOTTS40) or the pipe cutter (OOTAT), cut the pipe perpendicularly to its axis (fig. 5.14);
- 2 Mark the inserting depth on the pipe, as shown in table 5.13, using a suitable pen which does not nick the pipe surface (Fig. 5.15);
- 3 For **Alfaidro Aluminium pipes**, completely peel off the exterior layer first (PPR external layer and aluminium layer) (fig. 5.16-5.18), using the specific peeler (art. OOST). Make sure that the blades are in perfect conditions, otherwise replace them with original spare blades and carry out peeling to verify the proper setting of the new blade: it should not be easier than usual to push the peeled pipe into the welding matrix.



Figure 5.14



Figure 5.15

Table 5.13 - Inserting depth

Pipe diameter d_n (mm)	Inserting depth l_i (mm)
20	14
25	15
32	17
40	18
50	20
63	26
75	29
90	32
110	35



Figure 5.16



Figure 5.17



Figure 5.18

Push the end of the pipe into the guide of the peeling tool. Peel off the aluminium layer up to the stop of the peeling tool, which corresponds to the depth of insertion of the fitting (note that it is not necessary to mark the welding depth as the stop of the peeling tool indicates the correct welding depth).

Before starting the fusion, make sure that the aluminium layer has been completely removed.

4. Fix the proper tool on the welding machine and wait for the welding temperature to be reached . The optimum temperature is 260 ± 10 °C. Follow operating instructions carefully.

5. Use alcohol and a clean paper towel to thoroughly clean the outside and inside surface of the pipe and fitting to remove dust and dirt.

■ **Welding by manual welding machine**

Phase 1: after checking that the heating elements have reached the required temperature (260 °C ± 10 °C), simultaneously push the pipe into the female tool up to the mark and the fitting into the male tool up to the beat avoiding rotating them (fig. 5.19)

Hold the two elements firmly on the tool for all the heating time long, t_1 , as shown in table 5.14;

Phase 2: after the heating and within the recommended time t_2 , extract the two elements from the heating tool and joint gradually the pipe to the fitting avoiding rotating them and respecting the insertion depth (5.20);

Phase 3: hold the two elements firmly all the welding time long, t_3 , as shown in table 5.4;

Phase 4: let the welded elements cool at ambient temperature all the cooling time long, t_4 (never plunge into water or forcedly cool them). The welded joint can be mechanically stressed only after the cooling time.

After each welding operation, thoroughly clean the tool.

Following the above steps it will get a uniform and inseparable connection, it will last for all the service life of the pipeline (fig. 5.21)

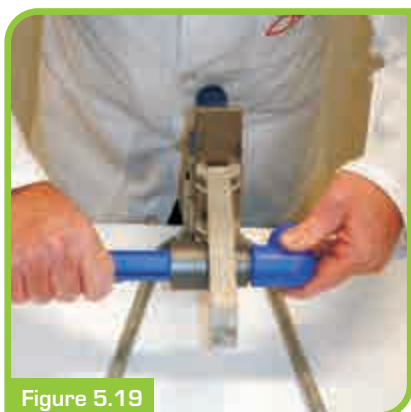

Table 5.4 - Heating, welding and cooling times

Pipe diameter d_n (mm)	Heating time t_1 (sec)	Removing and inserting time t_2 (sec)	Welding time t_3 (sec)	Cooling time t_4 (min)
20	5	4	6	2
25	7		10	
32	8	6	20	4
40	12			
50	18			
63	24	8	30	6
75	30			
90	40	10	50	8
110	50			



Figure 5.22

■ **Welding by bench-type welding machine**

Phase 1: fix the elements to weld into the machine cheeks and adjust the inserting depth.(fig. 5.22). After reaching the welding temperature ($260\text{ °C} \pm 10\text{ °C}$), insert the pipe into the female matrix and the fitting into the male one [fig. 5.23]. Hold the two elements firmly in this position all the heating time long, t_1 , as shown in table 5.4.

Phase 2: after the heating time, move away the heating element and gradually insert the pipe into the fitting, within the time t_2 (fig. 5.24).

Phase 3: hold the two elements firmly all the welding time long, t_3 , as shown in table 5.13

Phase 4: after the welding, release the cheeks, remove the welded elements and let them cool at ambient temperature all the cooling time long, t_4 . The welded joint can be mechanically stressed only after the cooling time.



Figure 5.23

■ **Saddle welding**

These fittings are an easy and reliable alternative to reducing tees, they can be installed directly on the outside of the pipe, making the installation more flexible and simple.

The saddles are used for:

- branch connections in existing installations
- branch connections in risers
- sensor wells and other instruments



Figure 5.25



Figure 5.24



Figure 5.26

1. Drill the pipe with the specific cutter (art. OOFRS) - fig. 5.25
2. In **Alfaidro Aluminium** pipes it is necessary to remove the aluminium in proximity of the hole with the specific deburring tool (art. STX);
3. After reaching the welding temperature ($260\text{ °C} \pm 10\text{ °C}$), insert the concave part of the heating tool into the drilled hole, until the tool is completely in contact with the external wall of the pipe and simultaneously insert the weld saddle into the convex part of the tool (fig. 5.26). Hold the two elements firmly in this position for 30 seconds.
4. Move away the heating element and gradually insert the saddle into the heated hole of the pipe (fig. 5.27).
5. Hold the saddle firmly, avoiding rotating it.
6. Let the weld elements cool at ambient temperature for 10 minutes. The weld joint can be mechanically stressed only after the cooling time.
7. Fit the appropriate branch pipe into the sleeve of the weld saddle using conventional fusion technology.



Figure 5.27

Welding check

Once the welding operation is complete, the joint has to be subjected to a visual check in order to make sure that it has the following characteristics:

- the bead has to be visible and homogeneous along the external surface;
- the pipe and the fitting have to be perfectly in line;
- the joint surface should not present weldless parts;
- the insertion of the pipe into the fitting has to be up to the marking line.

If irregularities are noticed, it is necessary to weld two new elements.

Precautions for fusion welding

- Never heat the pieces twice
- Make the welding at an ambient temperature between +5 °C and +40 °C.
- Protect the welding area from rain, wind, damp, strong solar radiation, etc.
- During the insertion, do not exceed the fitting beat in order to avoid the reduction of the pipe section.
- It is essential to let the welded elements cool at ambient temperature: a forced cooling, for example by water, might cause internal stresses compromising the welding resistance.

5.3.2 BUTT WELDING

The welding is carried out by simultaneously heating the side surfaces of two elements (pipes and/or fittings) with the same diameter; when the heating temperature is reached, the two pieces moved away from the heat source are joint by pressing them.

Preliminary operations

- 1** Thoroughly clean with a suitable detergent (isopropyl alcohol, methylene chloride) and a clean towel the outside and inside surface of the pipe and fitting in order to remove possible dust and dirt;
- 2** Fix the elements to weld into the machine cheeks, mill the ends to make them parallel and remove oxide. Follow the operating instructions carefully.
- 3** Remove the chips using a brush or a clean towel.

Avoid any contact with the surface to weld

- 4** Put the surfaces into contact and check that:

EXAMPLE

1. the circumference misalignment is less than 10% of the elements thickness and anyway not exceeding 2 mm; on the contrary, repeat the blocking and milling operations;
2. the light between the two ends is below the values shown in table 5.14; on the contrary repeat the blocking and milling operations.

Using the manometer supplied with the welding tool, gauge the necessary entrainment pressure P_t to make the machine support move: this value should not exceed the pressure P_1 (phase 1) and P_5 (phase 5) values listed in the machine technical data sheets.

- Clean the surfaces to weld again, if necessary.

Table 5.15 - Maximum light values after milling

Outside diameter d_e (mm)	Maximum light (mm)
$d_e < 200$	0,3
$200 \leq d_e < 400$	0,5



Figure 5.27

Welding parameters selection

The temperature is to be of $210^{\circ}\text{C} \pm 10^{\circ}\text{C}$

- The P_1 and P_5 value is to be such that the sum of $(P_1 + P_t)$ and $(P_5 + P_t)$, corresponding to the pressure applied to the surfaces in contact during the phases 1 and 5, is equal to 0.10 N/mm^2 .
- P_1 and P_5 depend on the welding tool type and can be worked out from the machine technical data sheet, whereas P_t is gauged experimentally.
- The P_2 value (phase 2) has to be such as to grant the contact between the surfaces and not to exceed 0.01 N/mm^2 .

Welding operation

Phase 1: Fix the thermolement on the machine, approach the parts to weld to it and press them $(P_1 + P_t = 0.10\text{ N/mm}^2)$ for a time t_1 , sufficient to make a bead of height h , as required in UNI draft standard and shown in the following table 5.16

Phase 2: Once the bead is made, stop pressing the surfaces against the thermolement up to the value $P_2 = 0.01\text{ N/mm}^2$ and keep them in contact for a time t_2 as shown in the table above;

Phase 3: Passed the heating time, move the thermolement away and put the surfaces in contact within the time t_3 (table 5.15);

Phase 4: Keep pressing up to $P_5 + P_t = 0.10\text{ N/mm}^2$ within the time t_4 ; keep pressing gradually so as to avoid an excessive coming out of the surfaces material;

Phase 5: Keep the surfaces in contact for the time t_5 ;

Phase 6: After the welding phase, move the joint away from the machine and let it cool down at ambient temperature avoiding any kind of stress.

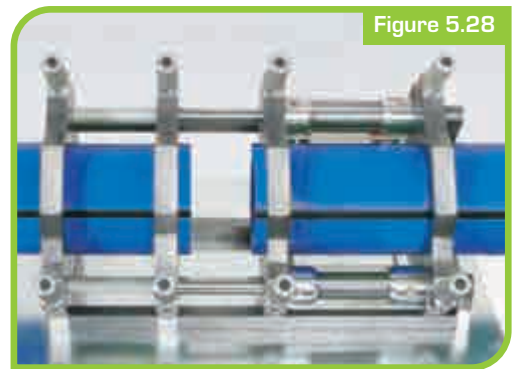

Figure 5.28

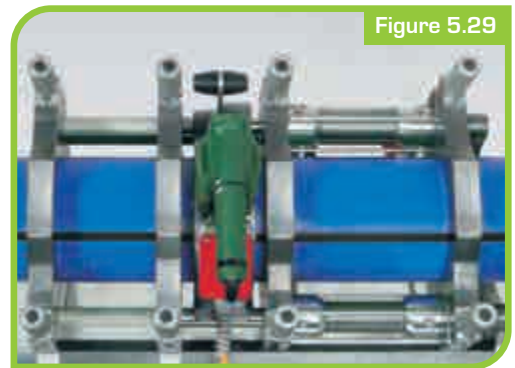

Figure 5.29

Table 5.16 - Welding parameters (draft standard UNI)

Wall thickness (mm)	Phase 1	Phase 2	Phase 3	Phase 4	Phase 5
	$(P_1 + P_t) = 0.10\text{ N/mm}^2$	$P_2 = 0.01\text{ N/mm}^2$		$(P_5 + P_t) = 0.1\text{ N/mm}^2$	
	Height of the bead h minimum (mm)	Heating time t_2 (sec)	Removal time t_3 max (sec)	Reaching of welding pressure time t_4 (sec)	Welding time t_5 minimum (sec)
2.0 - 4.5	0.5	60 - 135	4 - 5	5 - 6	3 - 6
4.5 - 7.0	0.5	135 - 175	5 - 6	6 - 7	6 - 12
7.0 - 12.0	1.0	175 - 245	6 - 7	7 - 11	12 - 20
12.0 - 19.0	1.0	245 - 330	7 - 9	11 - 17	20 - 30
19.0 - 26.0	1.5	330 - 400	9 - 11	17 - 22	30 - 40

■ Welding check

After the welding operations, the joint has to present the following characteristics:

- the bead has to be uniform all along the welding;
- the notch between the beads has to stay over the outside diameter of the joint: $e > 0$ (fig. 5.30);
- the bead outside surface has to be free from porosity, dust or any other contamination;
- no superficial cracks.



Figure 5.30

■ Precautions for butt-welding

- Carry out the welding operations at an ambient temperature of +5 and + 40° C;
- protect the area to weld from rain, wind, humidity and direct sunlight;
- do not force the cooling down using water, compressed air or other methods.

■ 5.3.3 ELECTRO-FUSION WELDING

This technique is generally used to repair or weld during the installation.

The electric resistance inserted into the fitting body is connected to the electro-fusion tool by means of two thermal pins. The heat generated by the current flowing through the resistance is sufficient to create the fusion between the sleeve and the pipe.

■ Welding by the electro-fusion tool

Operate as follows:

- Cut the pipe perpendicularly to its axis using the proper shear.
- Clean the pipe surface and use the scraper supplied with the welding tool to scrape the welding area, then smooth the pipe to remove the chips. During this and the following operations, avoid touching the welding area. The insertion depth has to be of 0,1/0,2 mm. Never use abrasive paper nor emery cloth because they could contaminate the pipe surface and compromise the welding:
- Insert the parts to weld into the sleeve up to the beat.
- Insert the welding pins into the sleeve, avoiding the cable weight resting on the joint.
- Start the welding tool following the manufacturer's instructions
- During the welding process and the following cooling phase, any stress on the pipes has to be avoided.
- Wait at least one hour after the welding operation before exerting any pressure on the installation.

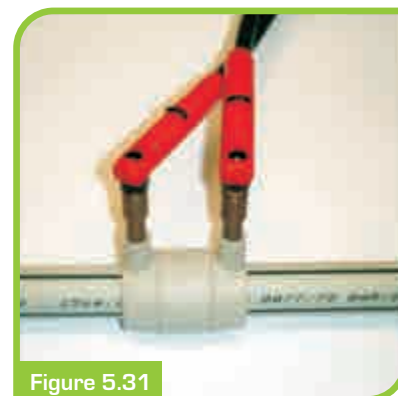

Figure 5.31

If the same sleeve has to be subjected to more than one welding cycle, it is necessary to wait for the complete cooling between one cycle and another.

■ Welding check

After the welding operations, the joint has to be subjected to a visual check in order to make sure that it has the following characteristics:

- the pipe and the fitting have to be perfectly in line;
- neither melted material nor the resistance have come out.

■ Precautions for electro-fusion welding

Make the welding at an ambient temperature of +5 up to +40 °C in a dry place and repaired from air.

Never use other sources (welding torch, burners, etc) to heat the elements.

Do not force the cooling down in anyway.



Figure 5.32

■ 5.3.4 HOLE REPAIR

If an **Alfaidro**, **Alfaidro FASER** or **Alfaidro Aluminium** pipe is accidentally perforated, it is possible to repair it using a special tool to be fixed on the welding tool and a special repairing patch supplied with the tool. Operate as follows:

- thoroughly clean the surfaces to repair;
- adjust the clamping screw according to the pipe thickness and avoid the male die touching the opposite side of the pipe;
- simultaneously insert the male tool into the hole to repair and the patch into the female tool (fig. 5.32);
- after the heating time (5 seconds), remove the two elements from the tool and insert the patch into the hole (fig. 5.33);
- let the welding cool and cut the patch part protruding out of the pipe (fig. 5.34).

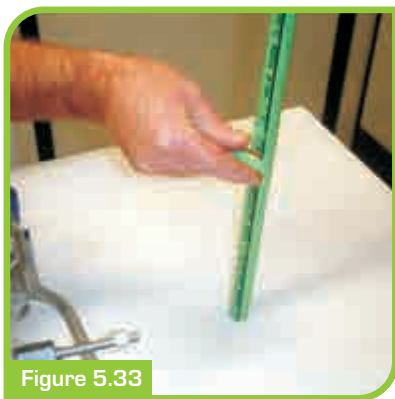

Figure 5.33

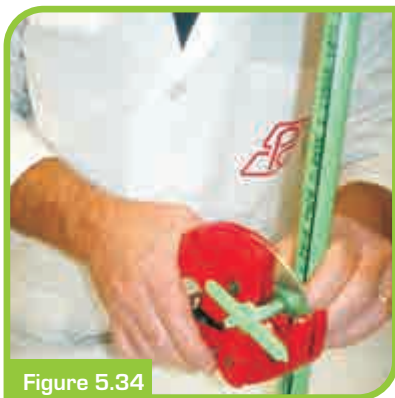

Figure 5.34

N.B. If the pipe hole is larger than the heating tool or it passes through one side to the other, cut the damaged length and repair the pipe using a common fitting or an electric sleeve.

Plastica Alfa cannot be held responsible for damages due to operations carried out disregarding the instructions or due to the use of not suitable tools.

5.3.5 JOINTING BY THREADED FITTINGS

The **Alfaidro system** includes fittings with conic threaded insert (UNI ISO 10226-1, -2 – ex ISO 7/1) that can be assembled to the metal parts possibly present in the system. Make sure that the thread size to be joined to our fitting complies with the above mentioned standard.

In order to grant a correct seal, teflon or liquid dopes can be used; do not use hemp because the increased thickness can damage the thread.

Teflon is to be wrapped around the male thread clockwise, whereas the liquid dope has to be uniformly distributed on the thread.



Figure 5.35

5.3.6 JOINTING BY FLANGES

The **Alfaidro** range includes also flanged fittings that allow a direct connection to systems and devices, such as pumps, generally supplied with flanged connections. **Flanged joints** are recommended for plastic piping systems that require periodic dismantling.

Insert the flange into the flange neck, then weld the flange neck to the pipe (par. 5.3.1 and 5.3.2) and join the other flange as follows:

- make sure that all the bolt holes of the flanges match up and insert all bolts.
- make sure that the faces of the flanges are not separated by excessive distance prior to bolting down the flanges.
- tighten the bolts by pulling down the nuts diametrically opposite each other using a torque wrench so as to apply uniform stress across the flange.



Figure 5.36

5.3.7 JOINTING BY GROOVED FITTINGS

The **Alfaidro system** is unique because the range includes the **Alfarapid** grooved joints and fittings. They are characterised by a special seal and can be assembled to grooved pipelines. The assembly is extremely easy: you need only to position the special seal between the elements to join, insert the clamp and screw the bolts.



Figure 5.37

5.4 SYSTEM INSPECTION

Once the system is installed, it is necessary to test it as prescribed by the standards existing in each countries (UNI 9182, EN 806-4, ENV 12108, DIN 1988,...).

The system test includes inspections to be carried out during the pipe laying on the parts that will become unaccessible and final tests and inspections once the system is installed.

5.4.1 HYDROSTATIC PRESSURE TESTING

Below is the method of the standard UNI ENV 120108.

The system should be filled slowly with drinking water to ensure the complete elimination of air pockets, thus preventing pressure surges.

For hydrostatic pressure testing, pressure gauges and the recording apparatus shall have an accuracy of 0,02 MPa (0,2 bar) and shall be fitted at the lowest point in the system. The pressure gauge has a range of 0 MPa to 1,6 MPa (0 bar to 16 bar).

When required, the system test pressure may be increased to comply with regulations.

A complete record of the details of the test (complete test procedure diagram) shall be made and preserved.

As a result of their material properties, plastics pipes expand for a limited period when pressurized, this influences the test result: a change in the temperature of the pipe system can result in a pressure change. For this reason the pressure tests should be done at an as much as possible constant test medium temperature. Alternative hydrostatic pressure tests for installed pipework systems and commissioning of such systems are given follow: procedure A and B respectively.

Test procedure A

- a) Open the venting system;
- b) purge the system with water to expel all air that can be removed thereby. Stop the flow and close the venting system;
- c) apply the selected hydrostatic test pressure equal to 1,5 times the design pressure by pumping according to Figure 5.38 during the first 30 min, during which time an inspection should be carried out to identify any obvious leaks with the system under test;
- d) reduce the pressure by rapidly bleeding water from the system to 0,5 times design pressure according to Figure 12;

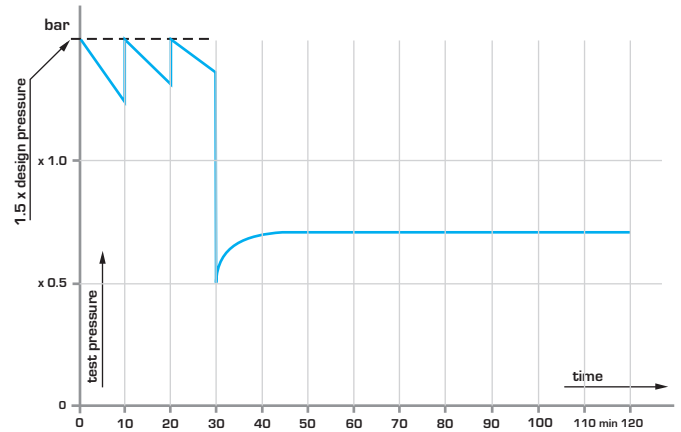
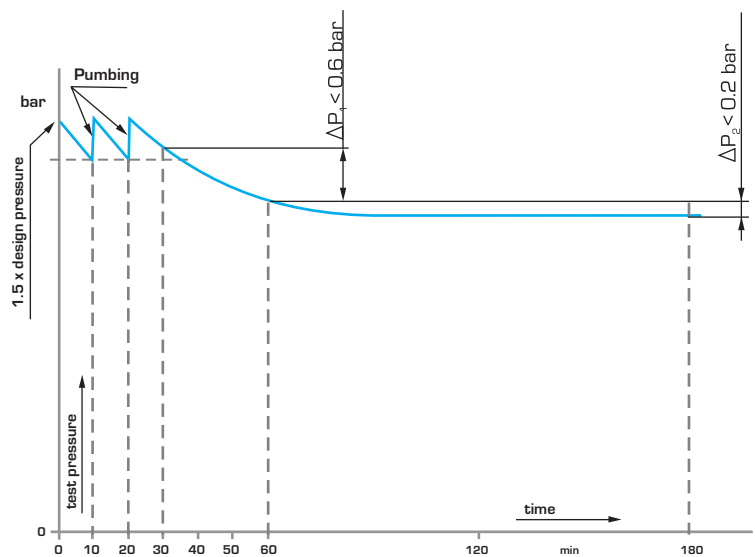

Fig. 5.38 Testing for water tightness - Test procedure A

- e) close the valve. The recovery of a constant pressure, which is higher than 0,5 times the design pressure, is indicative of a sound system. Monitor the situation for 90 min. Visually check for leaks. If there is a pressure loss, the system shall be maintained at the test pressure until the obvious leaks within the system are identified.
- f) the test result should be recorded.

Test procedure B

- a) Open the venting system;
- b) purge the system with water to expel all air that can be removed thereby. Stop the flow and close the venting system;
- c) apply the selected test pressure equal to 1,5 times the design pressure by pumping according to Figure 13 during the first 30 min;
- d) read the pressure when the first 30 min have elapsed;
- e) read the pressure after another 30 min and visually check for leaks. If the pressure has dropped by less than 0,6 bar conclude the system has no obvious leakage and continue the test without further pumping;
- f) visually check for leaks and if during the next 2 h, the pressure drops by more than 0,2 bar this indicates a leak within the system;
- g) the test result should be recorded.



5.39 Testing for water tightness - Test procedure B

For smaller sections of an installation the test Procedure B may be reduced to only stages a) to e) and g).

■ 5.4.2 SOUNDPROOFING TEST

Although the Alfaidro pipes and fittings are characterized by high soundproofing, it is necessary to check the noise produced by the discharges (generally in PVC).

The measurements of noise and vibration must be made in accordance with existing legislation.

■ 5.4.3. FLUSHING THE PIPEWORK

The drinking water installation shall be flushed with drinking water as soon as possible after installation and pressure testing and immediately before commissioning.

Cold and hot water pipes shall be flushed separately.

The water used for the flushing procedure shall be drinking water.

Where a system is not brought into use immediately after commissioning, it shall be flushed at regular intervals.

Flushing can be carried out in two ways:

- flushing with water
- flushing with a mixture of air and water

The flushing medium may be determined by local codes, engineering specifications, or the needs of the mechanical equipment used.

Where no requirements are established, potable water is sufficient for flushing **Alfaidro piping systems**.

5.5 INSTRUCTIONS AND WARNINGS

Following are given some suggestions to use **Alfaidro** pipes and fittings at their best.

■ **Transportation, storage and installation.** Try not to subject pipes and fittings to violent impacts, especially if the working temperature is below 0 °C since at low temperatures the material is more rigid and this reduces the resistance to external stresses. Store the pipes in piles at the most 1.5 mt height. The contact with sharp objects (like brick scabbling) must be avoided. In any case, discharge the damaged pipe length.

■ **Exposure to UV radiation.** It is recommended not to install or store the pipes in the direct UV rays since they trigger chemical reactions in PPR causing a premature ageing; it follows a worsening of the material physical, mechanical and chemical properties.

■ **Exposure to low temperatures.** It is recommended to drain the line when the water is expected to freeze, since the increase in volume might break the pipe.

■ **Bridging curves.** In case of pipe overlap use the bridging curves provided for **Alfaidro**.

■ **Bending.** Cold bending may be used when the bending radius is at least 8 times the pipe diameter, while for smaller bends it is necessary to heat the section using a blower of hot air. **NEVER USE THE FLAME.**

■ **Threaded joints.** Do not use fittings having tapered thread with fittings having cylindrical thread. To assure a good seal, wrap up with teflon or liquid dope, never use hemp.

■ **Operating conditions.** It is essential not to exceed the extreme operating conditions of Alfaidro pipes and fittings, otherwise the system life might be compromised. For this purpose, it is recommended to read the section 5.1. of this catalogue "Operating conditions".

Plastica Alfa declines any liability for damages caused by the non-observance of the instruction given above.

5.6 LAYING EXAMPLES



Fig. 5.40 Approximate example of distributing system in a private house.

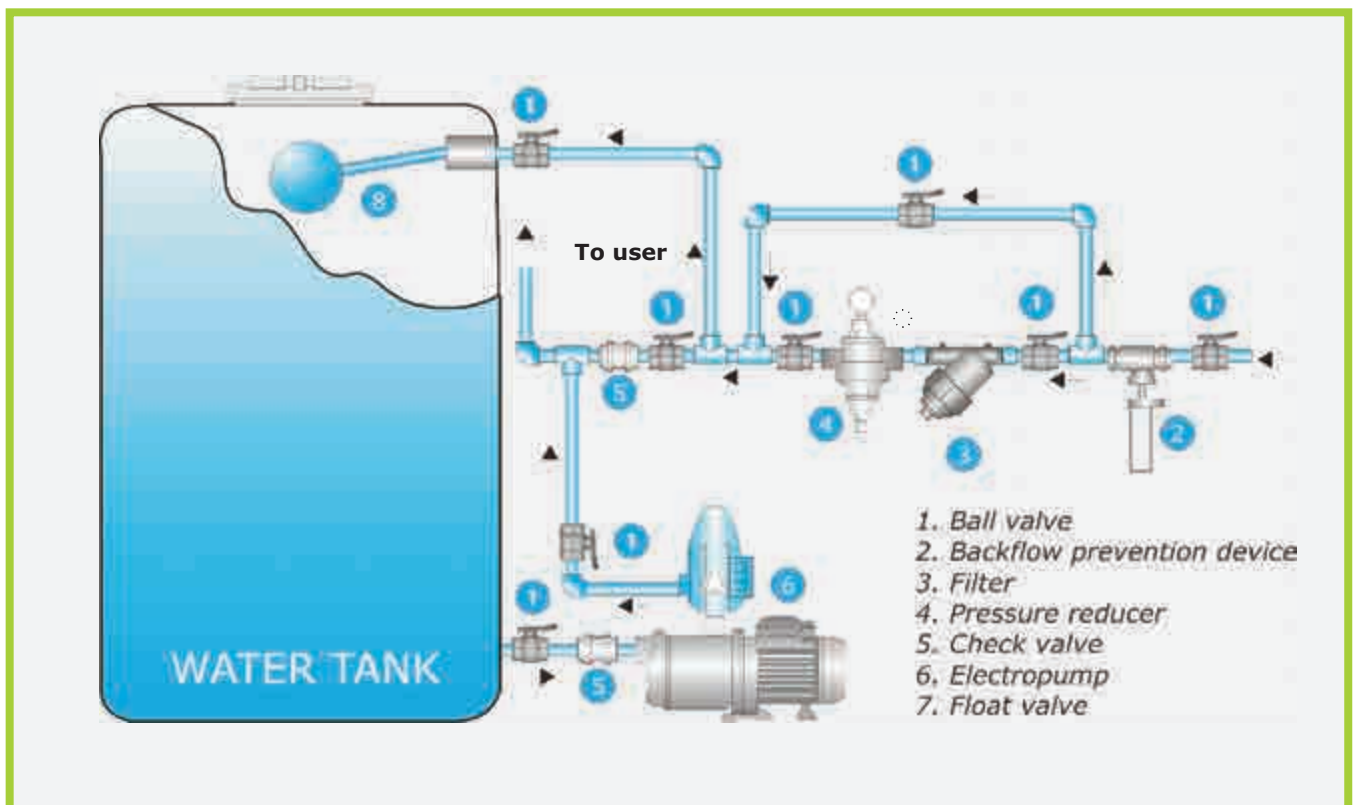

Fig. 5.41 Approximate example of autoclave.

ALFAIDRO

SYSTEM COMPONENTS 6



6.1 PIPES

Monolayer PPR Pipe ALFAIDRO SDR 11 - S5

10TA



ALFAIDRO
PP-R PIPES AND FITTINGS
SDR 11

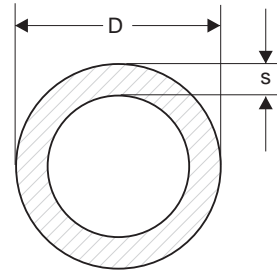

MARCATURA/MARKING

PLASTICA ALFA TUBI ALFAIDRO $\phi \times s$ A PPR SDR11 PN12.5 class 1 Operating conditions 60°C 7,5 bar UNI EN ISO 15874 - DIN 8077/78 LINEA date hour MADE IN ITALY

Application class and Service conditions according to UNI EN ISO 15874 - Class 1/6 bar \equiv Class 2/4 bar \equiv Class 4/6 bar for a service life of 50 years

Working temperature & Working Pressure	20°C - 15,4 bar	Outside diameter [D]	Rod	Pack	Nominal Wall Thickness [s]	Internal diameters	Water Content	Weight	DN
	60°C - 7,7 bar 70°C - 5,1 bar		mm	mt					
Range of permissible temperature	min -20°C max 95°C	32	3	45	2,9	26,2	0,539	0,260	25
		40	3	30	3,7	32,6	0,834	0,411	32
		50	3	21	4,6	40,8	1,307	0,637	40
		63	3	12	5,8	51,4	2,074	1,006	50
		75	3	12	6,8	61,4	2,959	1,404	60
Coefficient of linear thermal expansion	0.16 mm/mK	90	3	9	8,2	73,6	4,252	2,031	65
		110	3	6	10,0	90,0	6,359	3,011	80
		125	3	3	11,4	102,2	8,199	3,903	100
Thermal conductivity	0.24 W/mK	160	3	3	14,6	130,8	13,430	6,381	125

Monolayer PPR-CT Pipe ALFAIDRO SDR 7.4 - S3.2

CTTA



ALFAIDRO
PP-R PIPES AND FITTINGS
SDR 7,4 - S3.2

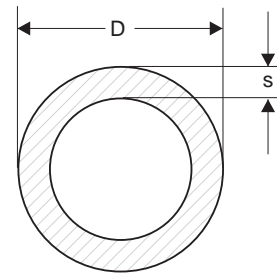

MARCATURA/MARKING

PLASTICA ALFA TUBI ALFAIDRO $\phi \times s$ A PP-RCT-SDR7,4 PN25 class 2/10bar Operating Conditions 70°C/12,5 bar UNI EN ISO 15874 - DIN 8077/78 LINEA date hour MADE IN ITALY

Application class and Service conditions according to UNI EN ISO 15874 - Class 1/10 bar \equiv Class 2/10 bar \equiv Class 4/10 bar \equiv Class 5/8 bar for a service life of 50 years

Working temperature & Working Pressure	20°C - 29,2 bar	Outside diameter [D]	Rod	Pack	Nominal Wall Thickness [s]	Internal diameters	Water Content	Weight	DN
	60°C - 15,4 bar 70°C - 13,1 bar		mm	mt					
Range of permissible temperature	min -20°C max 95°C	20	3	120	2,8	14,4	0,163	0,148	12
		25	3	75	3,5	18,0	0,254	0,230	15
		32	3	45	4,4	23,2	0,423	0,370	20
		40	3	30	5,5	29,0	0,660	0,575	25
		50	3	21	6,9	36,2	1,029	0,896	32
Coefficient of linear thermal expansion	0.16 mm/mK	63	3	12	8,6	45,8	1,647	1,408	40
		75	3	12	10,3	54,4	2,323	2,004	50
		90	3	9	12,3	65,4	3,358	2,869	60
Thermal conductivity	0.24 W/mK	110	3	6	15,1	79,8	4,999	4,298	65
		125	3	3	17,1	90,8	6,472	5,529	80
		160	3	3	21,9	116,2	10,599	9,036	100

*The pipes are suitable also for application CLASS 4 and CLASS 5, see section 3 "OPERATING CONDITION"

Monolayer PPR Pipe ALFAIDRO SDR 6 - S 2.5 PIPE

OOTA



PP-R PIPES AND FITTINGS
SDR 6
iip 302 UNI
UNI EN ISO 15874 - 5:2005
UNI EN ISO 15874 - 2:2008

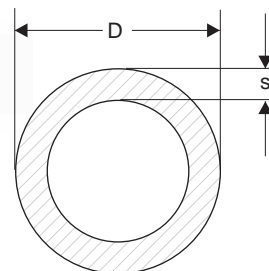

MARCATURA/MARKING

PLASTICA ALFA TUBI ALFAIDRO $\phi \times s$ A PPR SDR6 PN25 class 1/10bar - ATEC 14/14 219-2021 Classe 2/6bar Classe 4/10 bar Operating Conditions 70 °C/10 bar UNI EN ISO 15874 GERMAN STANDARD DIN 8077/70 LINEA date hour MADE IN ITALY
Application class and Service conditions according to UNI EN ISO 15874 - Class 1/10 bar = Class 2/8 bar = Class 4/10 bar Class 5/6 bar/for a service life of 50 years

Working temperature & Working Pressure	20°C - 30,9 bar 60°C - 15,5 bar 70°C - 10,2 bar	Outside diameter [D]	Rod	Pack	Nominal Wall Thickness [s]	Internal diameters	Water Content	Weight	DN
	Range of permissible temperature	min -20°C max 95 °C	mm	mt	mt	mm	mm	l/m	
Coefficient of linear thermal expansion	0.16 mm/mK	20	3	120	3,4	13,2	0.137	0.171	12
		25	3	75	4,2	16,6	0.216	0.264	15
Thermal conductivity	0.24 W/mK	32	3	45	5,4	21,2	0.353	0.431	20
		40	3	30	6,7	26,6	0.555	0.667	25
		50	3	21	8,3	33,4	0.876	1.036	32
		63	3	12	10,5	42,0	1.385	1.646	40
		75	3	12	12,5	50,0	1.963	2.331	50
		90	3	9	15,0	60,0	2.826	3.350	60
		110	3	6	18,4	73,2	4.206	5.022	65
		125	3	3	20,8	83,4	5.460	6.463	80
		160	3	3	26,6	106,8	8.954	10.576	100

Monolayer PPR Pipe ALFAIDRO SDR 5 - S2 PIPE

25TA



PP-R PIPES AND FITTINGS
SDR 5 - S 2

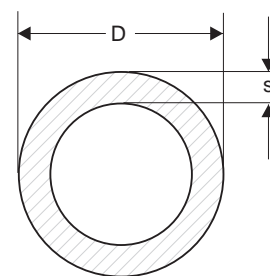

MARCATURA/MARKING

PLASTICA ALFA TUBI ALFAIDRO $\phi \times s$ A PPR SDR5 PN32 - class 2/10bar Operating Conditions 70°/12.5 Bar UNI EN ISO 15874 DIN 8077/70 LINEA date hour MADE IN ITALY
Application class and Service conditions according to UNI EN ISO 15874 - Class 1/10 bar = Class 2/10 bar = Class 4/10 bar Class 5/8 bar/for a service life of 50 years

Working temperature & Working Pressure	20°C - 39,8 bar 60°C - 19,5 bar 70°C - 12,8 bar	Outside diameter [D]	Rod	Pack	Nominal Wall Thickness [s]	Internal diameters	Water Content	Weight	DN
	Range of permissible temperature	min -20°C max 95 °C	mm	mt	mt	mm	mm	l/m	
Coefficient of linear thermal expansion	0.16 mm/mK	20	3	120	4,1	11,8	0.109	0.198	12
		25	3	75	5,1	14,8	0.172	0.306	15
Thermal conductivity	0.24 W/mK	32	3	45	6,5	19,0	0.283	0.497	20
		40	3	30	8,1	23,8	0.445	0.768	25
		50	3	21	10,1	29,8	0.697	1.197	32
		63	3	12	12,7	37,6	1.110	1.894	40

*The pipes are suitable also for application CLASS 4 and CLASS 5, see section 3 "OPERATING CONDITIONS"

Multilayer PP-RCT/PPGF/PP-RCT ALFAIDRO FASER PIPE - SDR 9 - S 4

CTTAF

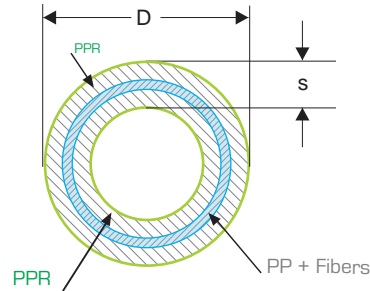

MARCATURA/MARKING

PLASTICA ALFA TUBI ALFAIDRO FASER ϕ x s A PPR-PPGF-PP-RCT SDR9 PN20 class 1/8bar Operating Conditions 70°/10bar UNI-EN ISO 15874 UNI-EN ISO 21003-2 DIN 8077/78 DIN16837 LINEA date hour MADE IN ITALY

Application class and Service conditions according to UNI EN ISO 15874 - Class 1/8 bar \equiv Class 2/8 bar \equiv Classe 4/8 bar \equiv Classe 5/6 bar for a service life of 50 years

Working temperature & Working Pressure	20°C - 23,1 bar 60°C - 12,2 bar 70°C - 10,4 bar	Outside diameter (D)	Rod	Pack	Nominal Wall Thickness (s)	Internal diameters	Water Content	Weight	DN
	Range of permissible temperature	min -20°C max 95°C	mm	mt	mt	mm	mm	l/m	
Coefficient of linear thermal expansion	0.035 mm/mK	32	4	48	3.6	24.8	0.483	0.321	25
		40	4	32	4.5	31.0	0.754	0.499	32
Thermal conductivity	0.24 W/mK	50	4	24	5.6	38.8	1.182	0.773	40
		63	4	12	7.1	48.8	1.869	1.232	40
		75	4	12	8.4	58.2	2.659	1.730	50
		90	4	8	10.1	69.9	3.825	2.493	65
		110	4	8	12.3	85.4	5.725	3.703	80
		125	4	4	14.0	97.0	7.386	4.773	80
		160	4	4	17.9	124.2	12.109	7.804	100

Multilayer PPR/PPGF/PPR ALFAIDRO FASER PIPE SDR 7.4 - S 3.2

10TAF

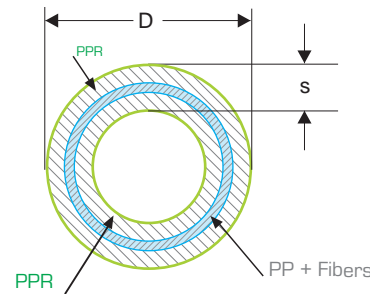

MARCATURA/MARKING

PLASTICA ALFA TUBI ALFAIDRO FASER ϕ x s A PPR-PPGF-PPR SDR7.4 PN20 class 1/8bar Operating Conditions 70°/8bar UNI-EN ISO 15874 UNI-EN ISO 21003-2 DIN 8077/78 DIN16837 LINEA date hour MADE IN ITALY

Application class and Service conditions according to UNI EN ISO 15874 - Class 1/8 bar \equiv Class 2/6 bar \equiv Classe 4/10 bar \equiv Classe 5/6 bar for a service life of 50 years

Working temperature & Working Pressure	20°C - 29,2 bar 60°C - 15,4 bar 70°C - 13,1 bar	Outside diameter (D)	Rod	Pack	Nominal Wall Thickness (s)	Internal diameters	Water Content	Weight	DN
	Range of permissible temperature	min -20°C max 95°C	mm	mt	mt	mm	mm	l/m	
Coefficient of linear thermal expansion	0.16 mm/mK	20	4	120	2.8	14.4	0.163	0.151	15
		25	4	80	3.5	18.0	0.254	0.236	20
Thermal conductivity	0.24 W/mK	32	4	48	4.4	23.2	0.423	0.379	25
		40	4	32	5.5	29.0	0.660	0.589	32
		50	4	24	6.9	36.2	1.029	0.917	40
		63	4	12	8.6	45.8	1.647	1.442	40
		75	4	12	10.3	54.4	2.323	2.052	50
		90	4	8	12.3	65.4	3.358	2.936	65
		110	4	8	15.1	79.8	4.999	4.401	80
		125	4	4	17.1	90.8	6.472	5.662	100
		160	4	4	21.9	116.2	10.599	9.255	

Multilayer PPR-AI-PPR ALFAIDRO ALUMINIUM PIPE - SDR 7.4 - S 3.2

OOTAL

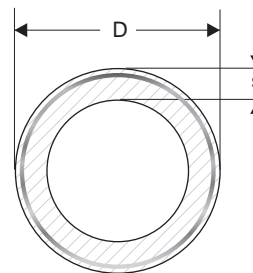

MARCATURA/MARKING

PLASTICA ALFA TUBI ALFAIDRO ALUMINIUM $\phi \times s \times l$ ext. A PPR-AI-PPR SDR7.4 PN20 class 1/8bar Operating Conditions 70°C/8bar UNI EN ISO 15874 UNI EN ISO 24003-2 DIN 8077/70 DIN16837 LINEA date hour MADE IN ITALY

Application class and Service conditions according to UNI EN ISO 15874 - Class 1/8 bar = Class 2/6 bar = Classe 4/10 bar = Classe 5/6 bar for a service life of 50 years

		Outside diameter (D)	Rod	Pack	Nominal Wall Thickness	Total Wall Thickness	Internal diameters	Outside diameters	Water Content	Weight	DN
		mm	mt	mt	mm	mm	mm	mm	l/m	Kg/m	
Working temperature & Working Pressure	20°C - 24,5 bar	20	4	120	2.8	3.6	14.4	21.6	0.163	0.201	15
	60°C - 12,3 bar	25	4	80	3.5	4.4	18.0	26.8	0.254	0.304	20
Range of permissible temperature	min -20°C	32	4	48	4.5	5.4	23.0	33.8	0.423	0.470	25
	max 95 °C	40	4	32	5.6	6.6	28.8	42.0	0.660	0.711	32
Coefficient of linear thermal expansion	0.030 mm/mK	50	4	24	6.9	7.9	36.2	52.0	1.029	1.055	40
		63	4	12	8.7	9.7	45.6	65.0	1.647	1.621	50
		75	4	12	10.4	11.4	54.2	77.0	2.323	2.257	50
		90	4	8	12.5	13.5	65.0	92.0	3.358	3.191	65
Thermal conductivity	0.24 W/mK	110	4	8	15.2	16.7	79.6	113.0	4.999	4.828	80

SDR 6 swan neck

00SO

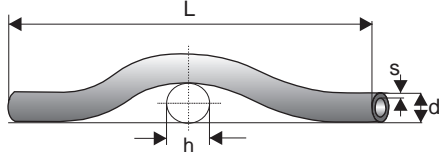

d	s	h	L
20	3.5	20.5	6.3
25	4.0	25.0	7.1
32	5.5	32.5	8.0

SDR 5 Swan neck

25SO

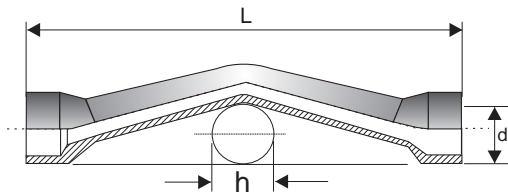

d	s	h	L
20	4.1	22	160
25	5.1	26	180

6.2 FITTINGS

The **Alfaidro fittings** comply with the standards **UNI EN ISO 15874-3** and **DIN 16962**.

Alfaidro fittings SDR 5 and **Alfaidro system** (pipes **SDR 6**+fittings **SDR 5**) are certified by **IIP** and **CSTBat**.



ATEC 14/14 - 219-2021

Table 6.1 Dimensional characteristics of ALFAIDRO fittings

FEMALE FITTINGS FOR SOCKET WELDING

Nominal diameter d_n (mm)	Mean inside diameter at the mouth (mm)	Maximum out-of-roundness (mm)	Minimum wall thickness (mm)		Minimum heated socket length (mm)
			SDR 6	SDR 5	
20	19.35 ± 0.15	0.4	-	4.1	14.5
25	24.35 ± 0.15	0.4	-	5.1	16.0
32	31.3 ± 0.2	0.5	-	6.5	18.1
40	39.2 ± 0.20	0.5	-	8.1	20.5
50	49.15 ± 0,25	0.6	-	10.1	23.5
63	62.2 ± 0.30	0.6	-	12.7	27.4
75 ¹	73.9 ± 0.30	1.0	-	15.1	31.0
90 ¹	88.9 ± 0.30	1.0	-	18.1	35.5
110 ¹	108.7 ± 0.30	1.0	18.3	22.1	41.5
125 ¹	123.65 ± 0.30	1.0	20.8	22.1	46.0

¹Type B socket

MALE FITTINGS FOR SOCKET WELDING

Nominal diameter d_n (mm)	Mean inside diameter at the mouth (mm)	Maximum out-of-roundness (mm)	Minimum wall thickness (mm)	Minimum heated socket length (mm)
			SDR 5	
20	20.15 ± 0.15	1.2	4.1	14.5
25	25.15 ± 0.15	1.2	5.1	16.0
32	32.15 ± 0.15	1.3	6.5	18.1
40	40.20 ± 0.20	1.4	8.1	20.5
50	50.25 ± 0.25	1.4	10.1	23.5
63	63.30 ± 0.30	1.6	12.7	27.4
75	75.35 ± 0.35	1.6	15.1	31.0
90	90.45 ± 0.45	1.8	18.1	35.5
110	110.50 ± 0.50	2.2	22.1	41.5

FITTINGS FOR BUTT WELDING

Nominal diameter d_n (mm)	Mean outside diameter (mm)	Maximum out-of-roundness (mm)	Minimum wall thickness		
			SDR11 (mm)	SDR7.4 (mm)	SDR 6 (mm)
160	160 - 161.5	3.2	14.6	21.9	26.6
200	200 - 201.8	4.0	18.2	27.4	33.2

Socket

13MA

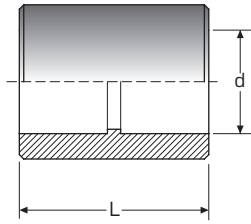

d	L
20	39
25	43.5
32	48.5
40	49.5
50	56.5
63	65
75	76.5
90	90
110	113.5
125	

M - F reducing bush

13RM

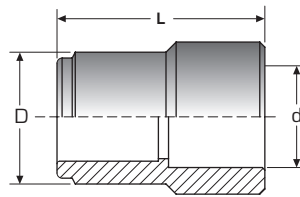

D-d	L
25-20	41
32-20	48
32-25	53.5
40-20	55
40-25	55
40-32	51
50-25	60
50-32	60
50-40	52
63-25	63.5
63-32	63.5
63-40	60.5
63-50	58
75-50	61
75-63	66
90-63	84.5
90-75	84.5
110-75	101.5
110-90	101.5
* 160-75	108.0
* 160-90	114.0
* 160-110	118.5
* 200-110	128.0
* 200-160	134.5

F - F reducing bush

13RF

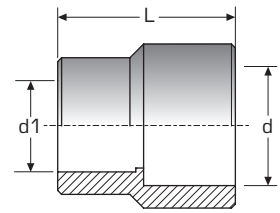

d - d1	L
25-20	38.5
32-20	48.5
32-25	52.5
40-20	38.5
40-25	43
40-32	48
50-32	61
50-40	55
63-20	58
63-25	64
63-32	66
63-40	59.5
63-50	60
75-50	76
75-63	76
90-50	80
90-63	84.5
90-75	84.5
110-75	101.5
110-90	101.5
125-90	115
125-110	118.5

90° F-F elbow

16G0

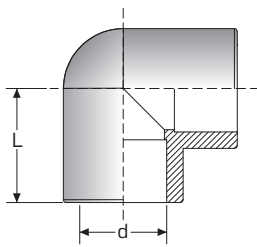

d	L
20	29.5
25	35
32	40
40	45
50	50
63	60
75	73
90	93
110	110
125	141.5
* 160	145
* 200	170

90° M-F elbow

16GP

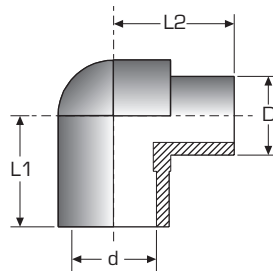

d	D	L1	L2
20	20	29	32.5
25	25	35	38
32	32	40	43

45° elbow

16GM5

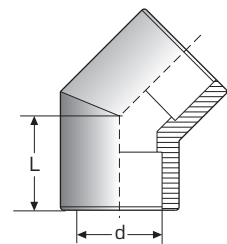

d	L
20	23
25	30
32	34
40	37
50	39
63	50
75	51
90	64
110	72.5
125	78.5
* 160	97
* 200	111

Tee

14TE

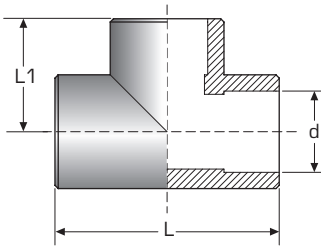

Reducing tee

14TR

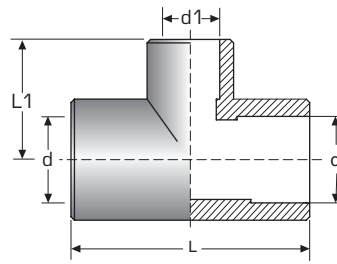

d	L	L1
20	59	29.5
25	70	35
32	79	39.5
40	89	44.5
50	101	50.5
63	122	61
75	145	72.5
90	190	94
110	220	110
125	282	141
160	290	145
200	340	170

dxd1xd	L	L1
25x20x25	70	30
25x20x20	70	30
25x25x20	70	30
32x20x32	81	30
32x25x32	81	35
32x20x20	81	30
32x20x25	81	30
32x25x20	81	35
32x25x25	81	35
32x32x25	81	40
40x20x40	89	44.5
40x25x40	89	44.5
40x32x40	89	44.5
40x20x25	89	44.5
40x32x25	89	44.5
40x32x32	89	44.5
40x40x32	89	44.5
50x25x50	101	50.5
50x32x50	101	50.5
50x40x50	101	50.5
50x20x50	101	43
50x40x40	10	50.5

dxd1xd	L	L1
63x20x63	122	61
63x25x63	122	61
63x32x63	122	61
63x40x63	122	61
63x50x63	122	61
75x50x75	145	60.5
75x63x75	145	64.5
90x50x90	190	69
90x63x90	190	72.5
90x75x90	190	75.5
110x50x110	220	90
110x63x110	220	95
110x75x110	220	98
110x90x110	220	102.5
* 160x90x160	290	130
* 160x110x160	290	135
* 200x63x200	340	240
* 200x90x200	340	250
* 200x110x200	340	260
* 200x160x200	340	270

Cross

14CR

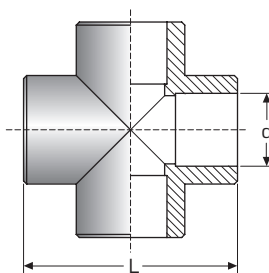

d	L
20	29.5
25	36
32	40
40	45
50	52

Cap

16CA

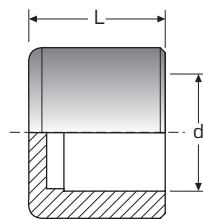

d1	L
20	24
25	29.5
32	32
40	30.5
50	38
63	43.5
75	48
90	54
110	60
125	68
* 160	78
* 200	90

Plug

16TA

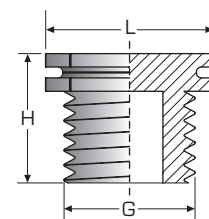

G	L	H
1/2"	25	25
3/4"	31	26.5
1"	38	32
1 1/4	48	34.5
1 1/2	53.5	34.5
2"	64	41
2 1/2	80	44

*Butt Welding

Pipe union

13BTP

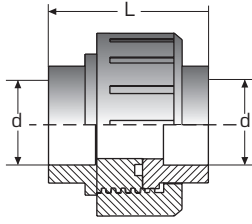

d	L
20	57
25	57
32	70
40	80
50	80

Extended plug

16TL

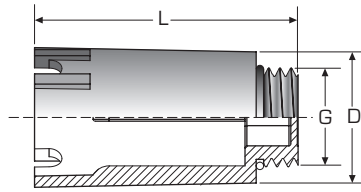

G	D	L
1/2"	31.5	70
3/4"	35	72.5

Pipe clip

OOGAN

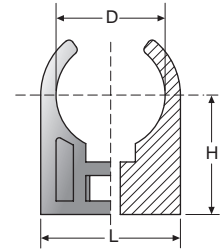

d	L	h
20	25	22
25	31	26
32	39	30
40	49	33
50	61	41
63	75	47

Weld saddle

13SL

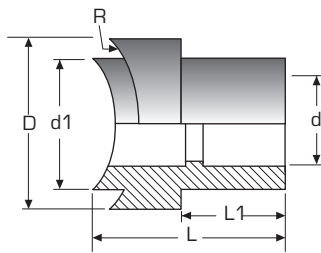

d x d1	R	D	L1	L
20 x 25	50	37.2	21.5	41.5
20 x 25	63	37.2	21.5	41.5
20 x 25	75	37.2	21.5	41.5
20 x 25	90	37.2	21.5	41.5
20 x 25	110	37.2	21.5	41.5
25 x 25	50	37.2	23	43
25 x 25	63	37.2	23	43
25 x 25	75	37.2	23	43
25 x 25	90	37.2	23	43
25 x 25	110	37.2	23	43
32 x 25	50	44	30	49
32 x 25	63	44	30	49
32 x 25	75	44	30	49
32 x 25	90	44	30	49
32 x 25	110	44	30	49

Weld saddle female threaded

13SLF

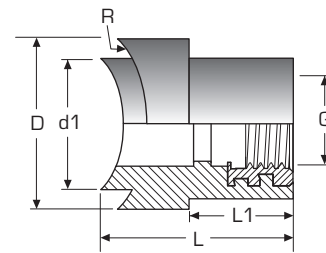

G x d1	R	D	L1	L
1/2" x 25	50	37.2	21.5	41.5
1/2" x 25	63	37.2	21.5	41.5
1/2" x 25	75	37.2	21.5	41.5
1/2" x 25	90	37.2	21.5	41.5
1/2" x 25	110	37.2	21.5	41.5
3/4" x 25	50	37.2	23.5	43.5
3/4" x 25	63	37.2	23.5	43.5
3/4" x 25	75	37.2	23.5	43.5
3/4" x 25	90	37.2	23.5	43.5
3/4" x 25	110	37.2	23.5	43.5

Male adaptor female thread
13FF

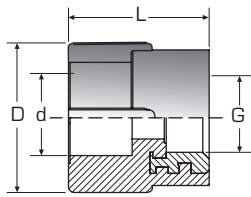

dxG	D	L
20x1/2"	38	40.5
20x3/4"	44	42
25x1/2"	47	47
25x3/4"	47	44.5
32x3/4"	47	44.5
32x1"	60	60
40x1"	55	49.5
40x1 1/4"	79.5	65
50x1 1/2"	79.5	74
63x1 1/2"	102	80
63x3/4"	102	80
63x2"	102	86
75x2 1/2"	112	76

Female adaptor male thread
13MF

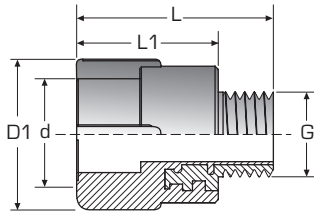

dxG	D1	L	L1
20x1/2"	38	55	40
20x3/4"	44	58	42.5
25x1/2"	44	62	47
25x3/4"	47.5	59	44
32x3/4"	47	58.5	44
32x1"	60	76	48.5
40x1"	55	67.5	49.5
40x1 1/4"	73	88.5	51.5
50x1 1/2"	79.5	97	58.5
63x2"	102	111.5	69
75x2 1/2"	110	105	61

Male adaptor male thread
13MM

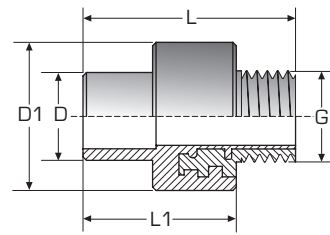

DxG	D1	L1	L
20x1/2"	35	40.5	55
25x1/2"	35	42.5	57.5
25x3/4"	43	45	60
32x3/4"	43	46.5	62.5
32x1"	52.5	50.5	68.5

Male adaptor female thread
13MF

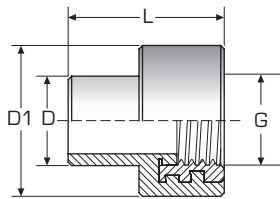

DxG	D1	L
20x1/2"	35	40.5
25x1/2"	35	42.5
25x3/4"	43	45
32x3/4"	43	46.5
32x1"	52.5	50.5

Male adaptor with hub
13MB

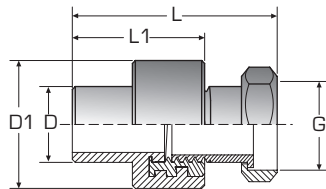

D1xG	D	L	L1
20x1/2"	-	-	-
20x3/4"	35	65	40.5
25x3/4"	35	67	42.5
25x1"	43	67	45
32x1"	43	75	46.5
32x1 1/4"	52.5	80	50.5

Female adaptor with hub
13FB

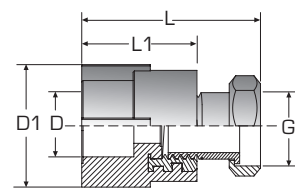

DxG	D1	L1	L
20x1/2"	40	40	71.5
20x3/4"	44	43.5	64
25x1/2"	44	43.5	73.5
25x3/4"	46.5	44	67
25x1"	46.5	44	66
32x1"	60	48.5	75
32x1 1/4"	60	48.5	87.5
40x1 1/4"	73	49.5	78

90° female elbow female thread
16GF

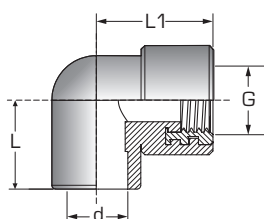

dxG	L	L1
20x1/2"	28	39.5
25x1/2"	35	46
25x3/4"	35	46
32x1/2"	40	40
32x3/4"	40	40
32x1"	45	45
40x1"	45	45

90° elbow with hub

16GB

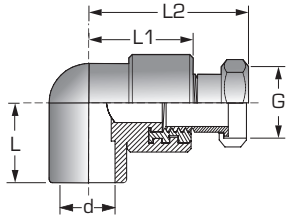

dxG	L	L1	L2
20x1/2"	28	39.5	62
20x3/4"	28	39.5	64
25x3/4"	35	46	70
25x1"	35	46	75
32x3/4"	40	40	65
32x1"	40	40	73.5
32x1"1/4	45	45	76
40x1"1/4	45	45	71

90° female elbow male thread

16GM

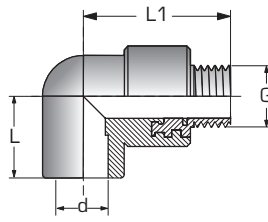

dxG	L	L1
20x1/2"	39.5	54
25x1/2"	46	50
25x3/4"	46	58
32x1/2"	40	54.5
32x3/4"	40	57.5
32x1"	45	63
40x1"	45	63
50x1"1/2	-	-

90° male elbow female thread

16GMF

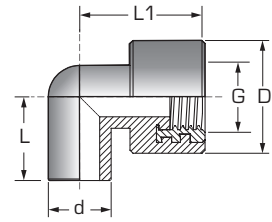

dxG	D	L	L1
20x1/2"	37.5	28	40

90° end elbow female thread

16GZ

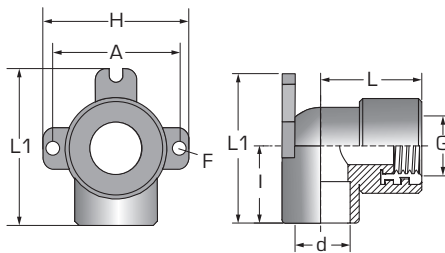

dxG	L	L1	I	H	A	F
20x1/2"	38.5	57	28.5	56	45	5
25x1/2"	45.5	67.5	35	64	52	5.5
25x3/4"	45.5	67.5	35	64	52	5.5

90° end elbow male thread

16GK

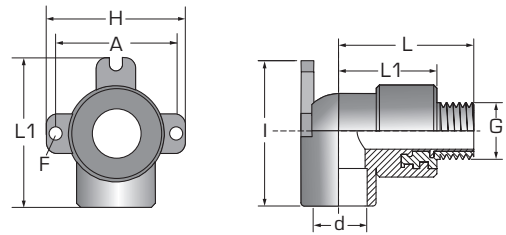

dxG	L	L1	I	H	A	F
20x1/2"	54	40	57	56	45	5
25x1/2"	62.5	45.5	67.5	64	52	5.5
25x3/4"	62.5	45.5	67.5	64	52	5.5

Tee female thread

14TF

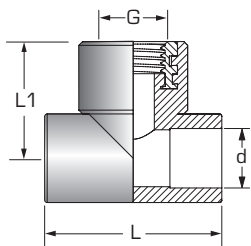

dxG	L	L1
20x1/2"x20	56	39
25x1/2"x25	70	35
25x3/4"x25	70	46
32x1/2"x32	79.5	40
32x3/4"x32	79.5	40
32x1"x32	89.5	46
40x1"x40	89.5	46

Tee male thread

14TM

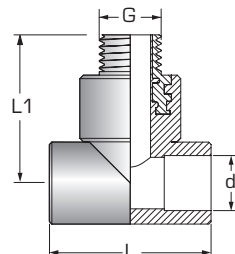

dxG	L	L1
20x1/2"x20	56	54.5
25x1/2"x25	70	51.5
25x3/4"x25	70	64
32x1/2"x32	79.5	58
32x3/4"x32	79.5	59.5
32x1"x32	89.5	64
40x1"x40	89.5	65.5

Tee with hub

14TB

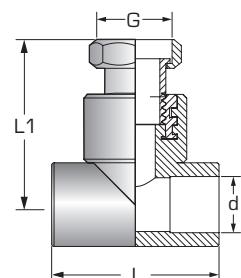

dxGxd	L	L1
20x1/2"x20	56	61
20x3/4"x20	56	63.5
25x3/4"x25	70	70
25x1"x25	70	64.5
32x3/4"x32	79.5	65.5
32x1"x32	89.5	68
32x1"1/4"x32	89.5	71.5
40x1"1/4"x40	89.5	77.5

3-5 way manifold

00CLT

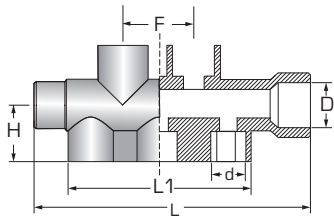

dxD	F	H	L	L1
20x32	48.5	45	189	122

Manifold with stop cocks

00CLT1

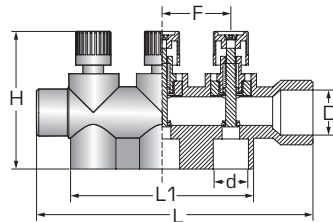

dxD	F	H	L	L1
20x32	48.5	88	189	122

Female threaded manifold

01CLT

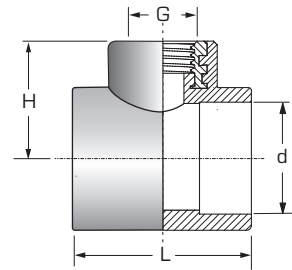

dxG	H	L
50 x 1"1/2	47	74.5
50 x 1"1/4	47	74.5
63 x 1"1/2	59	85.5
63 x 1"1/4	59	85.5

2-way female threaded manifold

02CLT

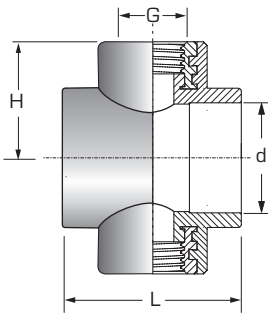

dxG	H	L
50 x 1"1/2	47	74.5
50 x 1"1/4	47	74.5
63 x 1"1/2	59	59
63 x 1"1/4	59	59

2-way female threaded manifold

00CLT2

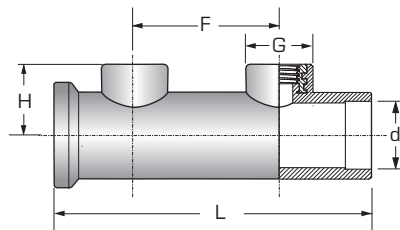

dxG	H	F	L
32 x 1/2"	44	48.5	189
63 x 1"1/2	45	111	250
63 x 1"1/4	45	111	250

4-way female threaded manifold

04CLT

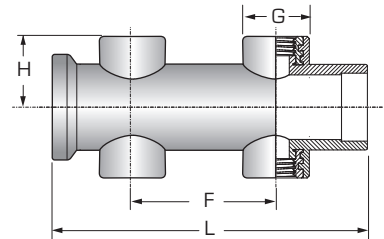

dxG	H	F	L
63 x 1"1/2	45	111	250
63 x 1"1/4	45	111	250

Female threaded template

00DIMA

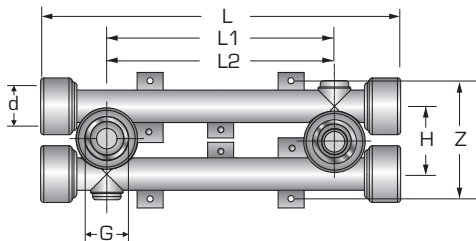

dxG	H	Z	L1	L2	L
20 x 1/2"	44	77	143	87	218

Shower Mixer

18MD1

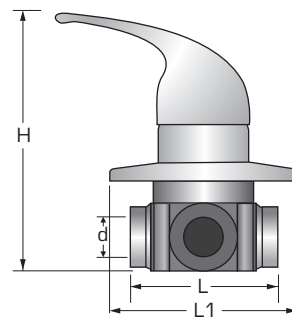

d	H	L1	L
20	150	95	100

Stop cock

18RA

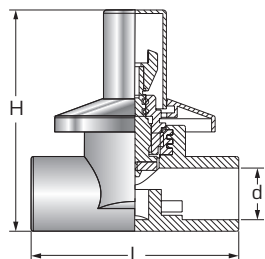

d L H

20	94	92.5
25	94	92.5

Extended stop cock with handle

18RT

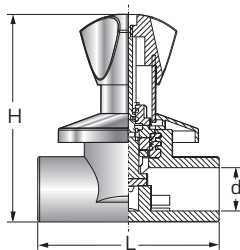

d L H

20	94	118
25	94	118

Ball valve with cap

18VS1

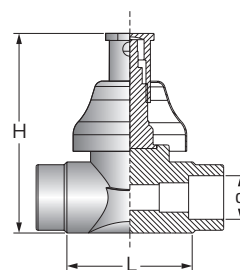

d L H

20	90.5	98.5
25	98.5	99
32	117.5	105.5

Ball valve with knob

18VS2

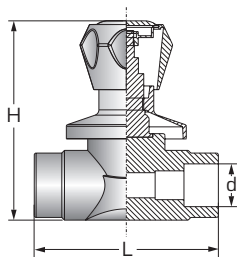

d L H

20	94	105.5
25	94	106
32	117.5	113

Ball valve with lever

18VS3

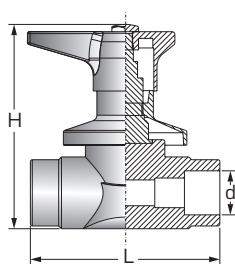

d L H

20	94	103
25	94	103
32	117.5	109.5

Stop cock

18RM

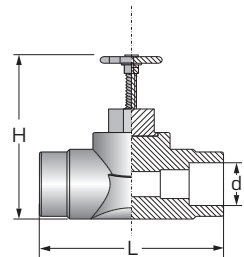

d L H

20	94	109
25	94	109
32	94	115

Ball valve

18VC

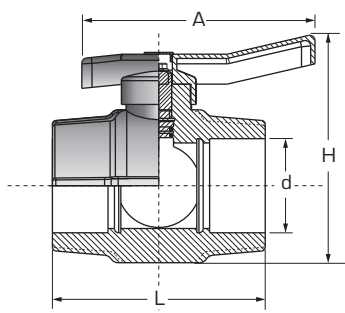

d L H A

20	73.5	74	84.5
25	77.5	74	84.5
32	89	92	108
40	97.5	105	108
50	112	114	108
63	131.5	150	150
75	151	162	150
90	186	197	187
110	214	215	305
125	240	285	305

Built-in ball valve

18VCI

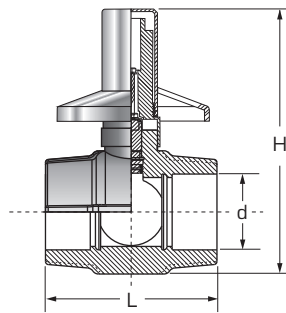

d L H

20	73.5	105
25	77.5	108
32	89	115

Built-in ball valve with handle

18VCI2

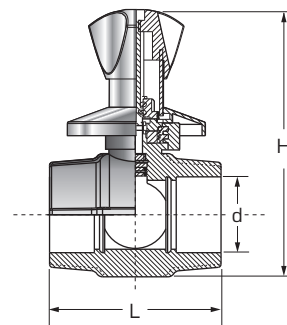

d L H

20	73.5	110
25	77.5	113
32	89	120

Backing ring

00FL

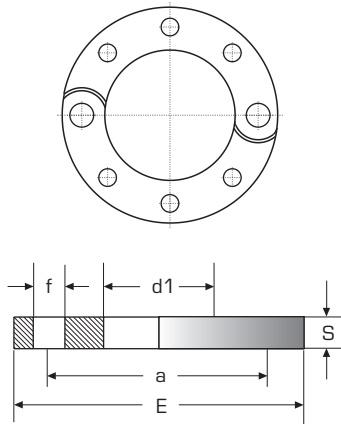

σ	dn	d1	s	a	f	E	U
1" 1/2	40	58	18	110	18	152	4
2"	50	76	18	125	18	165	4
2" 1/2	65	90	20	145	18	185	8
3"	80	107	20	160	18	200	8
4"	100	130.5	24	180	18	220	8
5"	125	164.5	26	210	18	250	8
6"	150	184	28	240	22	285	8

U = number of holes

Flange neck

13CPF

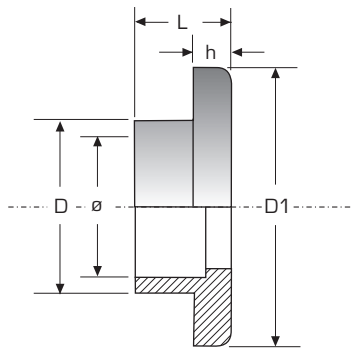

σ	D	D1	L	h
50	58.5	88	33	12
63	74.5	102	37	14
75	89.5	122	40	16
90	106.5	138	44	17
110	130	158	47.5	18
125	188	162	56.5	25
160	160	207.5	96.5	25

ALFARAPID Clamp Joint

AR1710

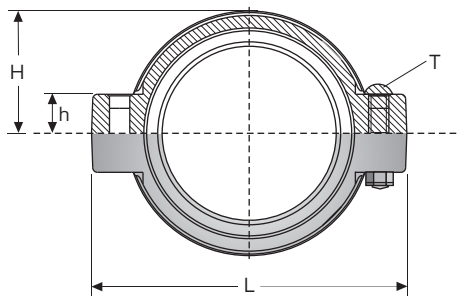

DN	DN		L	H	h	T
	in	mm				
1" 1/2	48.3	120	39.7	16	M10x50	
2"	60.3	133	46	16	M10x50	
2" 1/2	76.1	152	56	20	M10x50	
3"	88.9	174.5	62	25	M12x70	
4"	114.3	199.5	78	25	M12x70	
6"	168.3	281	106	28	M12x70	

Butt welding adaptor

AR213

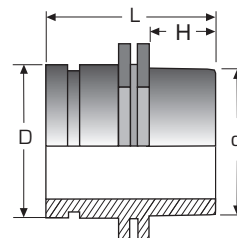

DN x d	Dn x d		H	L
	in	mm		
2"x50	2"x1 1/2	60.3x50	26.5	81.5
2"x63	2"x2"	60.3x63	30.5	85.5
2"x75	2"x2 1/2	60.3x75	33.5	88.5
2" 1/2 x 63	2" 1/2 x 2"	76.1x63	30.5	87.5
2" 1/2 x 75	2" 1/2 x 2 1/2	76.1x75	33.5	90
3"x75	3"x2 1/2	88.9x75	33.5	90
3"x90	3"x3"	88.9x90	40	97
3"x110	3"x4"	88.9x110	66.5	123.5
4"x90	4"x3"	114.3x90	40	100
4"x110	4"x4"	114.3x110	66.5	126.5

6.3 TOOLS

1 SYSTEM CHARACTERISTICS

2 STANDARDS AND QUALITY

3 OPERATING CONDITIONS

4 DESIGN

5 INSTALLATION

6 SYSTEM COMPONENTS

7 SERVICE AND GUARANTEE

Fixed thermostat welding tool

OOPOLIF



Electronic welding tool

OPOLEL



Bench-type welding machine

OOSABANC



Thermostat welding Kit ø 20÷32

OOSA



Thermostat welding Kit ø 63÷125

OOSA



Level template

DIMA



Cutting nippers virax

OOTTS



Roller pipe-cutter

OOTAT



Deburring tools

O0930



Peeler

OOST



Deburring tool for Aluminium

OOSTX



Hole mender

OOMARF



Cutter for saddle welding

OOFRS



Set of heating tools

OOMP



Saddle welding tools

OOMRS



ALFAIDRO

SERVICE
AND GUARANTEE

7



The company offers the experience of qualified personnel able to solve any possible problem that might arise during the installation of the products by giving all the necessary technical instructions.

Moreover, thanks to the technical staff's constant service.

Plastica Alfa offers innovative and customised solutions for the customers' needs.



7.1 GUARANTEE

ALFAIDRO pipes and fittings are guaranteed against possible damages due to manifest defects in the manufacturing process.

Plastica Alfa guarantees a compensation of max. **Euro 1.600.000,00** for damages coming from the use of **Alfaidro pipes and fittings** exceptionally faulty.

The guarantee is valid for **10 years** dating from the time of installation of the system.

The insurance policy does not cover any possible damage caused by:

- installations carried out without respect towards the technical instructions;
- wrongly done welding operations or carried out by not suitable tools;
- welding of Alfaidro pipes or fittings with similar products not manufactured by **Plastica Alfa**;
- installation of pipes and fittings in spite of manifest signs of deterioration due to bad storage and handling (i.e. scratching or squashing over tolerance limit);
- use for the conveyance of corrosive liquids at rash conditions and concentrations or not included in the table.

In case of damage, the user has to send a notice in writing to **Plastica Alfa** immediately; he must not tamper with the system in order to avoid losing the right to the possible compensation for damages.

In order to benefit by the guarantee conditions, ask the distributor for the certificate of guarantee that shall be forwarded to the producer duly filled in with the following data:

- the installing company's name;
- place and date of installation;
- user's and distributor's stamp and signature.

Any claim and contest will not be accepted if the certificate of guarantee has not been previously filled in .





1 SYSTEM CHARACTERISTICS

2 STANDARDS AND QUALITY

3 OPERATING CONDITIONS

4 DESIGN

5 INSTALLATION

6 SYSTEM COMPONENTS

7 SERVICE AND GUARANTEE

Available colours  Blue  Green | Please specify the colour required

Alfaidro PPR pipes and fittings in blue colour are CSTBat and IIP certified.

Length

- 1 mm = 0,03937 in
- 1 in = 25,4 mm
- 1 ft = 30,48 cm
- 1 m = 3,28 ft
- 1 mile = 1609,3 m
- 1 yard = 0,9144 m

Area

- 1 m² = 1,55 x 10³ in²
- 1 in² (sq.in) = 6,45 x 10⁻⁴ m²
- 1 Ara = 100 m²
- 1 Ettaro = 10000 m²
- 1 m² = 10,76 ft²

Volume

- 1 m³ = 6,1 x 10⁴ in³ (cu. in.)
- 1 in³ (cu. in.) = 1,6 x 10⁻⁵ m³
- 1 m³ = 35,28 ft³ (cu.ft.)
- 1 ft³ (cu. ft.) = 2,8 x 10⁻² m³
- 1 gal british = 4,545 dm³ (lt.)
- 1 gal USA = 3,785 dm³ (lt.)
- 1 pint british = 0,568 dm³ (lt.)

Weight

- 1 ounce az. (oz) = 28.35 g
- 1 lb. = 453.59 g
- 1 ton Brithish = 1016 kg
- 1 ton USA = 907 kg
- 1 dm³ (lt.) di acqua = 1000 g
- 1 ft³ (cu ft.) di acqua = 62.425 lb
- 1 gal USA of water = 8.33 lb
- 1 gal british of water = 10.04 lb

Pressure

- 1 bar = 10⁵ Pa (N/m²)
- 1 bar = 100 kPa
- 1 bar = 0,1 Mpa
- 1 bar = 0.99 Atm
- 1 bar = 1.02 kg/cm²
- 1 bar = 2300 oz/in²
- 1 bar = 3,3 x 10⁴ oz/ft²
- 1 bar = 14,5 lb/in²
- 1 bar = 10,2 m H₂O
- 1 Atm = 760 mmHg = 10.33 mH₂O
- 1 Atm = 1.033 kg/cm²
- 1 Atm = 14,696 lb/in² (PSI)
- 1 PSI (lb/in²) = 0.0680 Atm
- 1 Atm = 406.69 in H₂O = 33.89 ft H₂O

Flow

- 1 lt./sec.= 15,85 gal USA per min
- 1 ft³ per sec = 448.83 gal USA per min = 1698,82 lt./min
- 1 m³/h = 16,66 lt./min= 0,27 lt./sec
- 1 lt./min = 0,2642 gal/min

Power

- 1 kW = 1,36 CV = 1,341 HP
- 1 HP = 737 ft x lb/sec
- 1 CV = 0,735 kW = 0,986 HP
- 1 HP = 542 ft x lb/sec
- 1 HP = 0,745 kW = 1,013 CV
- 1 CV = 550 ft x lb/sec

Temperature

- t°C = T°K - 273,16
- T°K = t°C + 273,16
- t°C = 5/9 x (T°F - 32)
- T°F = 9/5 t°C + 32
- t°C = 5/4 x T°Re
- T°Re = 4/5 t°C
- t°C = 5/9(T°R - 491,688)
- T°R = 9/5 t°C + 491,688

For thermo-hydraulics **Plastica Alfa** offers also the **MULTYPEXALFA PEX-AI-PEX** system .

MULTYPEXALFA is designed for the conveyance of pressure water and it can be used in sanitary systems, traditional heating systems, air conditioning systems, radiators heating, cooling systems and gas conveyance. It can be also used in compressed air systems, greenhouses and gardening, alimentary fluids conveyance and industrial applications.



MULTYPEXALFA



MULTYPEX
THERMO



MULTYPEX
Air



MULTYPEX
SUPERPLUS



MULTYPEX
THERMOPLUS



MULTYPEX
protek



MULTYPEXALFA
gas



MULTYPEXALFA
gas protek

MULTYPEXALFA is a multilayer pipe made of **3 layers** joint through an adhesive; the intermediary layer is constituted by an aluminium foil (butt-weld during the extrusion) that makes the pipe totally oxygenproof, also conferring higher resistance to pressure, under-pressure and crashing although maintaining its ductility; the organoleptic properties of the fluids conveyed remain unchanged.



In addition to the full range of multilayer pipes, **Plastica Alfa** offers to resellers and installers a complete range of brass fittings, manufactured according to the international standards: different types of brass manifolds, brass threaded fittings, valves, stopcocks and plastic and metal manifold boxes. Also available presses, spring benders and chamfering calibrators, pipe unwinders and different types of pipe cutters. **MULTYPEXALFA SYSTEM is certified by IIP.**



absolutely made in italy



Sistema di Gestione per la
Qualità
UNI EN ISO 9001:2008



Sistema di Gestione
Ambientale
UNI EN ISO 14001:2004



Member of Green
Building Council Italia



PLASTICA ALFA

Zona Industriale C.da Balchino - P.O. BOX 121- 95041 CALTAGIRONE (CT) Italy
Tel. +39.0933.51973/50175/50159 - FAX +39.0933.53049
e-mail: info@plasticalfa.it - exportdpt@plasticalfa.it



www.plasticalfa.it

